

The logo consists of three stylized 'S' characters. The first 'S' is black and the largest. The second 'S' is red and smaller, positioned in front of the first. The third 'S' is black and the same size as the first, positioned to the right of the second.

S.R. & S.C. SCHEYER

A.B.N.- 80712611497

RIGGING

A Guide to Rigging

1. Rigging
2. Certification
3. Occupational health and safety

Second edition 1997

Disclaimer

This publication contains information regarding occupational health, safety, injury management or workers compensation. It includes some of your obligations under the various workers compensation and occupational health and safety legislation. To ensure you comply with your legal obligations you must refer to the appropriate Acts.

This publication may refer to administered legislation that has been amended or repealed. When reading this publication you should always refer to the latest laws. Information on the latest laws can be contact 1300 656 986.

Foreword

This competency guide has been developed jointly by the worksafe Authority.

It is a major revision of the old and widely respected NSW publication, *A guide for riggers*. It has been structured to reflect the nationally uniform certificate classes for rigging and conform to the standards for rigging set out in the *National OHS Certification Standard for Users and Operators of Industrial Equipment*. The text is also consistent with the nationally uniform assessment instruments used by certificate assessors and a range of Australian Standards which cover equipment and work involved with rigging.

This guide is designed to be a useful reference for trainee riggers, certificated riggers, leading hands and rigging supervisors, training providers, certificate assessors, and government inspectors.

CONTENTS	PAGE
	1
Introduction	5
PART ONE GENERAL RIGGING PRINCIPLES	7
1. Flexible steel wire rope	8
2. Winches sheaves and purchases for flexible steel wire rope	25
3. Natural fibre rope and slings	37
4. Synthetic fibre rope and slings	48
5. Chain	55
6. Anchorages and fittings	62
7. General rigging appliances	72
8. Slinging and working loads	80
9. Selection and use of mobile cranes	93
10. Packing, securing and moving loads	103

PART TWO BASIC RIGGING **109**

- 11. Steel erection 111
- 12. Cantilevered crane loading platforms 125
- 13. Erection of hoists and mast climbers 128
- 14. Industrial safety nets 134
- 15. Safety line systems 138
- 16. Handling pre-cast concrete 143

PART THREE INTERMEDIATE RIGGING **145**

- 17. Tilt-up panels 147
- 18. Multiple crane lifting 153
- 19. Demolition rigging 156
- 20. Rigging cranes and hoists 164

PART FOUR ADVANCED RIGGING **179**

- 21. Fabricated hung scaffolds 181
- 22. Suspended scaffolds 184
- 23. Gin poles and derricks 195
- 24. Span ropes and flying foxes 205

APPENDICES **209**

- (i) Personal safety equipment and first aid 211
- (ii) Communication and signals 213
- (iii) Areas and volumes 215 (iv) Tables of masses 219
- (v) Glossary 221
- (vi) Sample assessment questions 237

Index **241**

Introduction

Rigging is work involving the use of mechanical load shifting equipment and associated gear to move, place or secure a load including plant, equipment or members of a building or structure and to ensure the stability of those members and the setting-up and dismantling of cranes and hoists.

There are four certificate levels involved in rigging:

- Dogging
- Basic rigging • Intermediate rigging
- Advanced rigging.

This guide outlines the competency based skills needed to carry out basic, intermediate and advanced rigging safety. Basic rigging incorporates the skills needed for dogging. Refer to *A guide for dogging*,

Basic rigging

Those qualified in basic rigging must know how to carry out work associated with:

- movement of plant and equipment
- steel erection
- particular hoists
- placement of pre-cast concrete
- safety nets and static lines
- mast climbers
- perimeter safety screens and shutters
- cantilevered crane loading platforms.

Intermediate rigging

Those qualified in intermediate rigging must know how to carry out work associated with all basic rigging competencies and:

- the rigging of cranes, conveyors, dredges and excavators
- all hoists
- tilt slabs
- demolition
- dual lifts.

Advanced rigging

Those qualified in advanced rigging must know how to carry out work associated with all basic and intermediate rigging competencies and:

- the rigging of gin poles and shear legs
- flying foxes and cableways
- guyed derricks and structures
- suspended scaffolds and fabricated hung scaffolds.

Occupational health and safety

Under occupational health and safety legislation in each of Australia's states and territories:

- employers must provide and maintain equipment and systems of work that are safe and without risk to health
- employers must provide the correct equipment so that rigging work can be carried out safely
- employees must take care for the health and safety of themselves and fellow workers and cooperate with their employer while at work.

This guide

This guide aims to:

- prepare readers to pass an examination for basic, intermediate and advanced rigging certificates
- provide the basic knowledge to help the reader to carry out rigging work safely
- be used as a reference book when carrying out rigging work.

In addition to covering all rigging competencies there is a 'Glossary of Terms', a set of 'Sample Assessment Questions' and an index to assist the reader.

Part one General rigging principles

Chapter 1 Flexible steel wire rope

Introduction

Flexible steel wire rope (FSWR) is the link between the crane and the load.

The hoist drum of the crane is the pulling mechanism which rotates, hauls in and stores surplus wire. The braking mechanism is connected to either the drum or the gearing which is joined to the drive mechanism.

The wire passes over the head sheave of the crane and then down to the load.

There are many different types of lays and construction of FSWR to combat fatigue and abrasion, the two destructive forces which occur whenever FSWR is bent over a system of sheaves.

Wire flexes as it bends over sheaves and drums. As the wire bends over the sheave fatigue takes place. The outer wires are stretched and the inner wires are crushed against the sheave groove or drum.

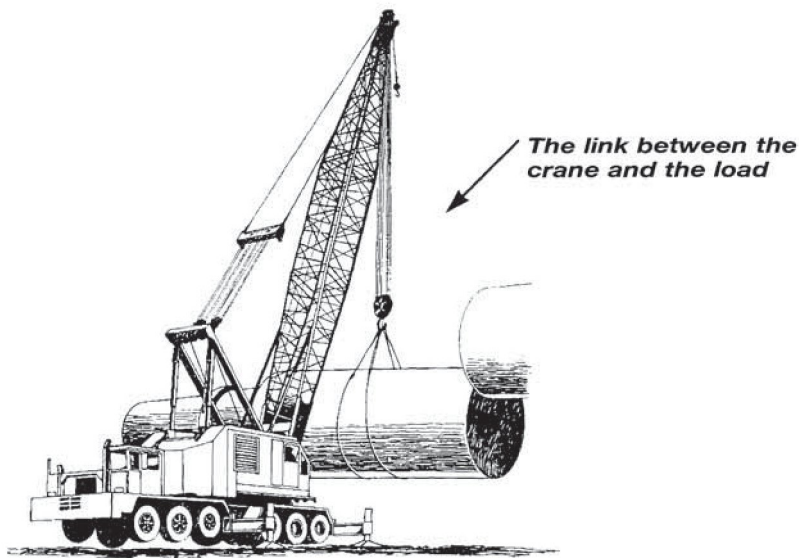

Wire never lays straight into the groove of a sheave because the load swings slightly or the rope vibrates. This causes friction or abrasion between the side of the sheave and the wire, wearing the outer wires of the strands.

Flexible steel wire rope - lays and construction

FSWR is constructed of wires and strands laid around a central core. In the illustration below there are 19 wires to the strand and 6 strands around the core making up the rope.

It is important not to confuse wires and strands. If a strand is broken, the rope is unusable. A single broken wire in a sling is not as important unless broken immediately below a metal fitting or anchorage.

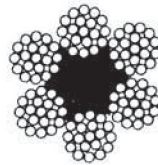

6 x 19 Construction FSWR

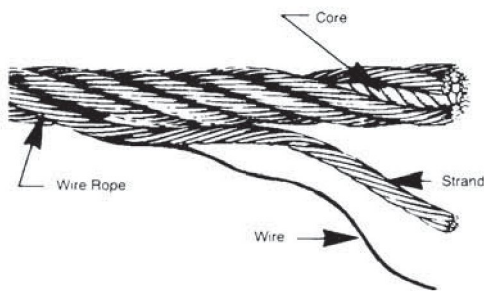

Composition of wire rope

The core can be:

- Fibre Core (FC)
- Independent Wire Rope Core (IWRC)
- Plastic Core (PC)

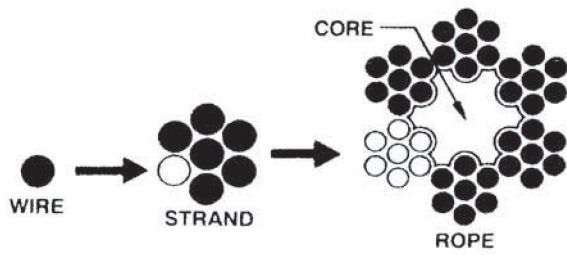

The tensile strength of wire ranges from 1220 megapascals (MPa) to 2250 MPa. The most commonly used tensile strengths are 1770 MPa and 1570 MPa.

A 6/19 (six strands of 19 wires each) is the minimum FSWR construction that can be used for slings.

The size of a rope is determined by its diameter. The smallest diameter FSWR that can be used for lifting is 5 mm.

Lay is the direction the wires are formed into strands and the strands are formed into the finished rope.

The strands can be laid either left or right around the core. In left hand lay the strands are laid anti-clockwise and in right hand lay they are laid clockwise.

Ordinary lay is where the wires are laid in the opposite direction to the strands.

Lang's lay is where the wires are laid in the same direction as the strands. There is therefore:

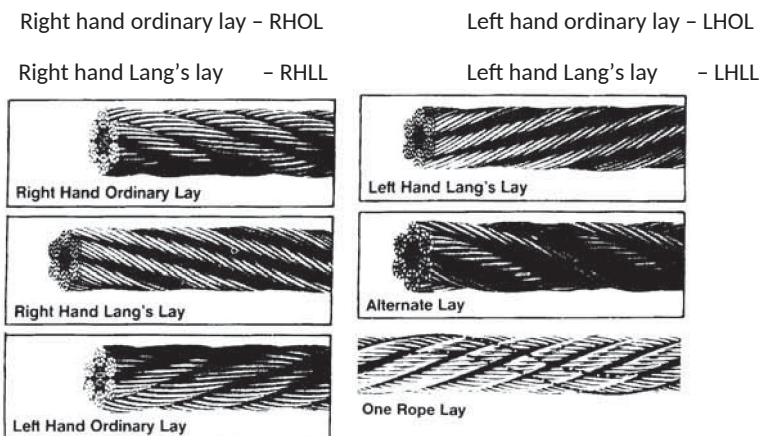

Lay does not affect the working load limit of the rope but it does determine characteristics such as the spin of the rope.

Lang's lay is used where both ends are fixed to prevent rotation such as for luffing. It must not be used for lifting. (Inspection for birdcaging at the anchorage point must be done regularly.)

Most general purpose ropes are right hand ordinary lay.

Pre- and post-forming

Flexible steel wire ropes that are used as crane rope and for slinging are either pre- or post-formed.

Pre-formed ropes have the spiral (helix) put in the individual wires before the wire is laid into the strand.

Post-formed ropes are put through a series of off-set sheaves to bend the spiral into the individual wires after the rope is laid into the strand.

Both pre-formed and post-formed ordinary lay ropes are more resistant than unformed or Lang's lay to unlaying when cut.

Lang's lay FSWR

Lang's lay is more flexible and harder wearing than ordinary lay ropes. It is used as excavator, dragline, and pile driving ropes where severe abrasion occurs. It is harder wearing because more of the individual wires are exposed to the sheaves.

Lang's lay has a tendency to unlay if it is used as a single fall crane rope because both wires and strands are laid up in the same direction into the rope. Pre- and post-forming make the rope easier to handle but it will still unlay under load.

Ordinary lay FSWR

Ordinary lay ropes are used extensively for slinging.

They are more resistant to unlaying and have less wire exposed to sheaves because of the opposite spiral. They are also more resistant to crushing and kinking because of the very short length of exposed wires.

Ordinary lay ropes are less resistant to abrasion than Lang's lay.

Left hand lay FSWR

A manufacturer may make up a FSWR with left hand lay strands on request. Left hand lay ropes are usually made for a special purpose. They will kink and twist when laying up into a purchase or system of sheaves if they are not laid up in the opposite direction to right handed lay.

Non-rotating ropes

Under load all FSWRs have a tendency to unlay including pre- or post-formed and ordinary or Lang's lay.

To prevent unlaying a left hand lay rope is layed inside a right hand lay rope. This is called a non-rotating ordinary lay rope and is usually used as crane rope. Under strain the opposite spiral in both the inner and outer layers are counter balanced and the rope does not twist.

Core slippage

Non-rotating ropes require careful handling. If the outer strands slip or unlay slightly the core will protrude from the end of the rope. This is called core slippage.

Core slippage can occur if the ends of the rope are not properly whipped before making a cut. Whippings of annealed wire must be put on either side of where the cut is to be made.

The whippings should be put on with a serving mallet very tightly for a distance of at least 1 to 2 times the rope diameter each side of the cut for ropes to 24mm diameter and 4 times for ropes over 24mm diameter.

Core slippage can occur as a wire is rope around a thimble for splicing. The outer wires may 'birdcage' or open up as the rope is bent around the small diameter thimble. It is preferable to use large diameter thimbles.

The rope should be tightly served (bound) with marlin or spun yarn for the distance of the length around the thimble, plus twice the length of the annealed wire flat throat seizing.

The seizing should be put on both parts of the rope immediately after securing the thimble into the served eye of the rope. The length of the throat seizing should be equal to at least 3 times the rope diameter.

Severe core slippage can occur when bending non-rotating ropes into wedge socket anchorages due to the small radius of the wedge.

If a wedge socket is used on a non-rotating hoist fall the rope should be frequently inspected.

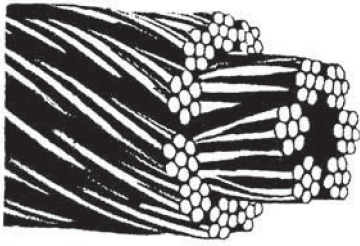

Core slippage

Handling

Non-rotating ropes are counter balanced to stop the tendency to twist or spin either way. However they are very pliable and bad handling can put turns into the rope.

As turns are put into a rope the outer strands become shorter and the inner core slips along and protrudes from the end and the outer strands bulge into birdcaging. The inner core therefore takes all of the load and may break.

Non-rotating ropes can be used successfully as single and multi-fall crane hoist ropes. However birdcaging at the anchorage is a common fault when they are reeved up as luffing ropes.

Installation

There is a danger of kinking or putting turns into the uncoiled rope when uncoiling it from the manufacturer's spool or reel.

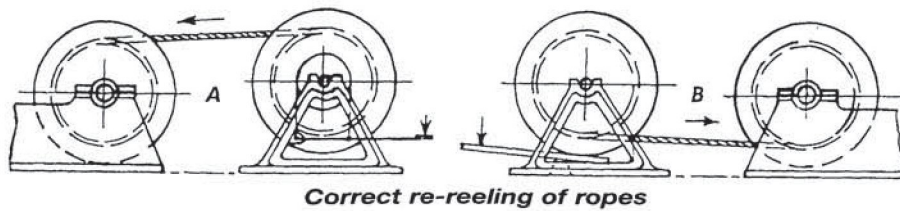

Correct re-reeling of ropes

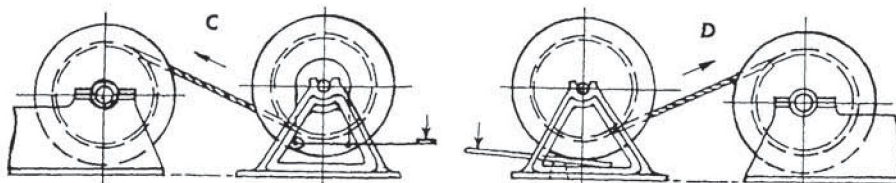

Incorrect re-reeling of ropes

If a loop forms in the slack rope a kink will form as the rope is drawn tight, or wound on to a drum. Therefore this section of the rope should be discarded.

Mount reels or spools onto a shaft so that the reel will revolve when the rope is pulled off. Care should be taken to brake the spool to keep tension on the rope as it is removed.

Non-rotating constructions

Three common multiple strand, non-rotating ropes are:

17 x 7 N.R – 11 (strands) of (6/1) over 6 (strands) of (6/1) over hemp core.

18 x 7 N.R – 12 (strands) of (6/1) over 6 (strands) of (6/1) over hemp core.

34 x 7 N.R – 17 (strands) of (6/1) over 11 over 6 of (6/1) over hemp core.

Non-rotating ropes prevent spin in nearly all circumstances.

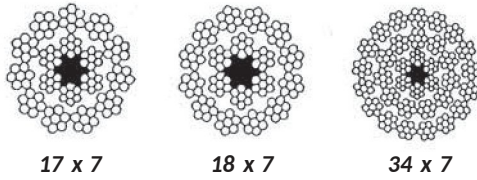

Construction types

Traditionally, round strand Lang's and ordinary lay FSWR have been constructed of:

- 6 strands of 19 wires (6 X 19)
- 6 strands of 24 wires (6 X 24)
- 6 strands of 37 wires (6 X 37).

Four strand ropes are also being used in newer cranes and hoists which have the same number of wires as six and eight strand ropes.

Most FSWR are parallel or equal laid with the inner wires in the strand laid in a longer spiral so that the top wires do not cross the inner wires.

To prevent a different spiral in the inner and outer wires of strands and to obtain parallel lay, different size wires are laid into the same strand. The standard constructions which use this method are:

- **Seale**

Large diameter wires are laid up on the outside and smaller wires are laid up on the inside over a central core wire. The large wires resist abrasion and the small wires give flexibility.

- **Warrington**

Alternative large and small wires are laid up on the outside of the strand combining flexibility and resistance to abrasion.

- **Filler**

A number of wires are laid over a central wire and an equal number of very small wires are laid in the valleys of these wires. Larger wires are then laid in the valleys between the large and small wires.

Seale and Warrington, and Filler and Seale have been combined to make 'Warriflex' and 'Seale-Filler' which both have greater flexibility combined with resistance to abrasion.

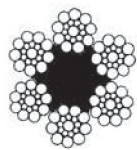

6 x 19 Seale
(9/9/1)



6 x 19 Warrington
(6 & 6/6/1)

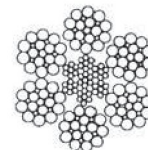

6 x 21 Filler Wire
with I.W.R.C
(10/5 & 5/1)

6 x 19 Rope group constructions

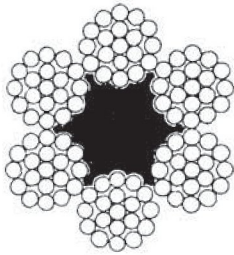

6 x 19 (12/6/1) F.C.

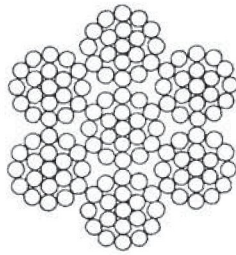

7 x 19 (12/6/1) W.S.C.

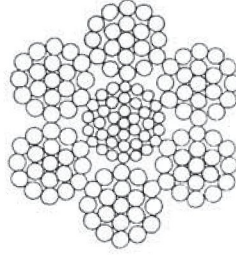

6 x 19/1 x 37 F.S.C.

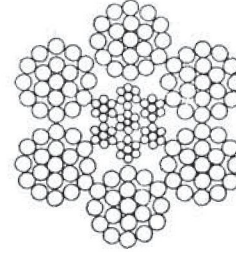

6 x 19/7 x 7 I.W.R.C.

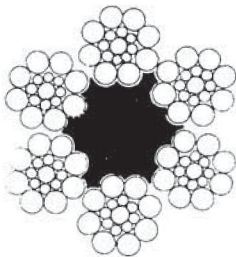

6 x 17 S (8/8/1) F.C.

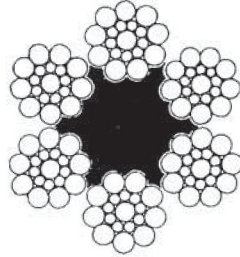

6 x 19 S (9/9/1) F.C.

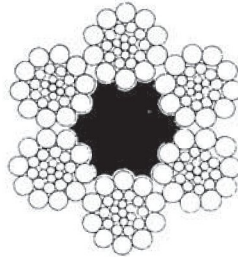

6 x 27 S (10/10/6/1) F.C.

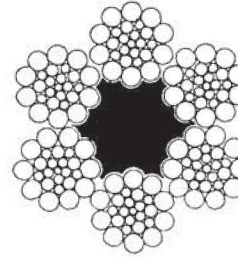

6 x 26 S.W. F.C.

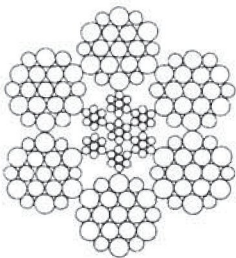

6 x 19 W (6 & 6/6/1)
I.W.R.C.

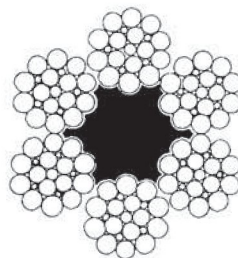

6 x 21 F.W. (10/5 + 5/1) F.C.

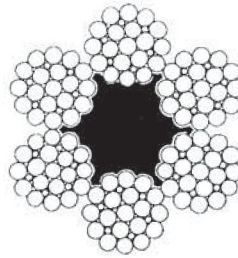

6 x 25 F.W. (12/6 + 6/1) F.C.

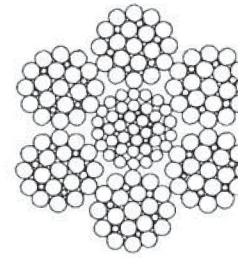

6 x 25 F.W./1 x 43 F.S.C.

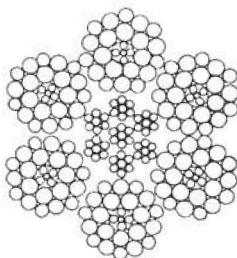

6 x 25 W (7 & 7/7/4/1)
I.W.R.C.

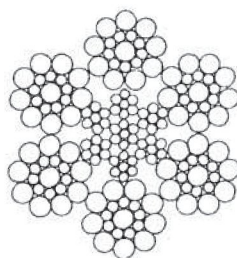

6 x 19 S (9/9/1)
I.W.R.C.

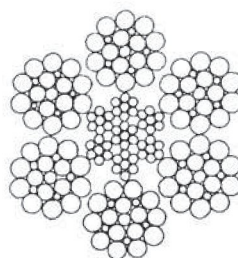

6 x 21 F.W. (10/5 + 5/1)
I.W.R.C.

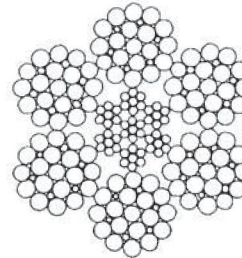

6 x 25 F.W. (12/6 + 6/1)
I.W.R.C.

6 x 37 Rope group constructions

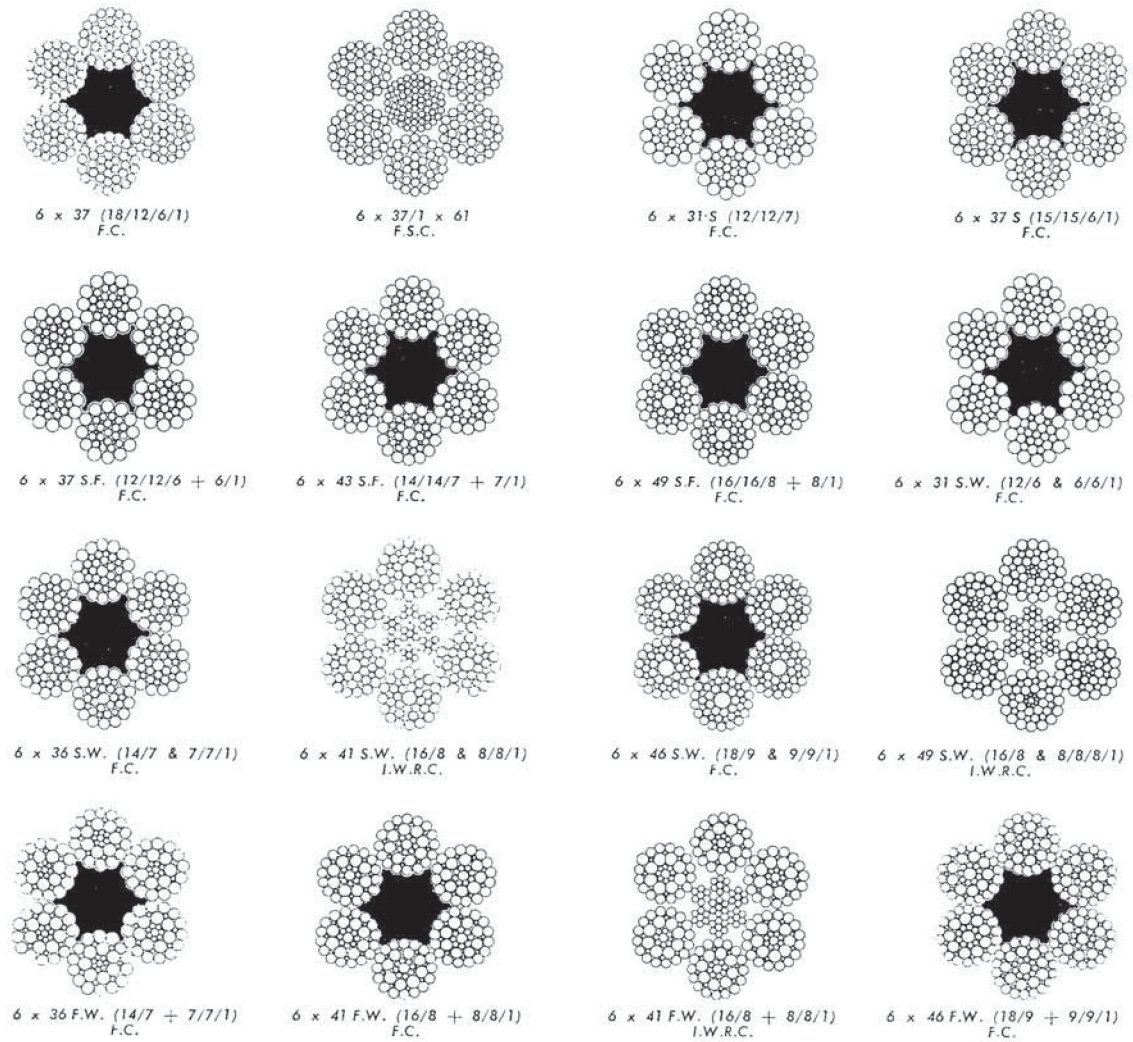

8 x 19 Rope group constructions

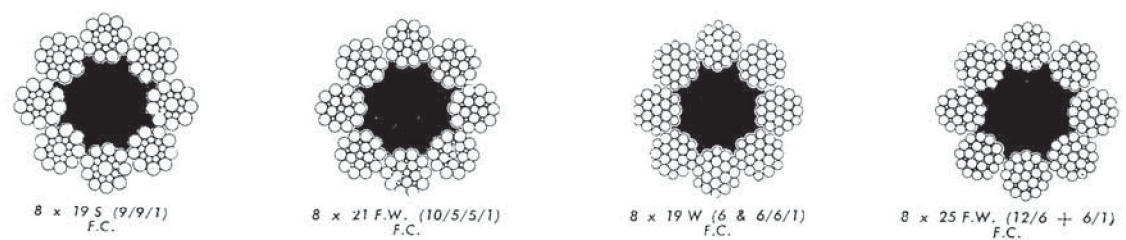

Rope inspection

When inspecting ropes inspect the whole system not just the FSWR. Ropes can be affected by:

- physical and mechanical factors such as abrasions, fatigue, reverse bends and so on
- environmental conditions such as the weather, salt air, freezing conditions, extreme heat, steam, acid vapours, dust and so on.



1. Mechanical damage due to rope 6. Typical wire fractures as a result of bend fatigue.

movement over sharp edge projection whilst under load.

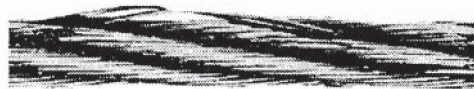

2. Localised wear due to abrasion on 7. Wire fractures at the strand, or core interface, supporting structure. Vibration of rope as distinct from 'crown' fractures, caused by between drum and jib head sheave. failure of core support.

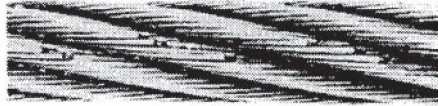

3. Narrow path of wear resulting in fatigue 8. Typical example of localised wear and fractures, caused by working in a grossly deformation created at a previously kinked oversize groove, or over small support portion of rope rollers.



4. Severe wear in Lang's lay, caused by points on multi-torsional unbalance. Typical of build-up layer coiling application. seen at anchorage end of multi-fall crane

application.

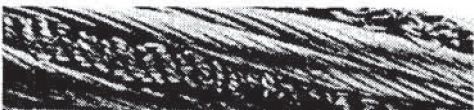
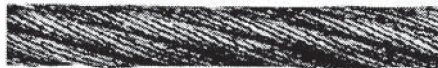

5. Severe corrosion caused by immersion of 10. Protrusion of IWRC resulting from rope in chemically treated water. shock loading.

Broken wires

As the rope lays into a sheave friction occurs and the outside of the wires wear and become flat. Langs lay ropes are much less prone to outer wire wear than ordinary lay.

As outer wires wear and the wire rope is bent over sheaves the fatigue will start to break them.

The maximum number of broken wires allowed in a FSWR is 10 per cent of the total number of wires over a length 8 times the diameter of the rope.

For example: 25mm diameter / 6 x 19 Seale.

Diameter = 25mm

$25 \times 8 = 200\text{mm}$ length

Total wires in 6 x 19 = 114 wires 10 per cent of 114 =

11.4 wires

Maximum number of broken wires allowed in a length of 200mm = 11

Condemn any FSWR showing broken wires in the valleys between the strands (an indication of extreme fatigue).

Condemn a FSWR where there is one broken wire at the start of any anchorage. This is a sign of localised fatigue.

Crane or luffing pendant ropes should be checked for broken wires. Although they do not pass over sheaves they are subject to fatigue due to vibration.

If there are three or more broken wires in eight rope diameters the pendant should be inspected by a rope expert.

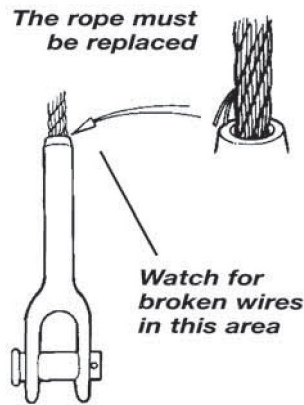

Reduction in diameter

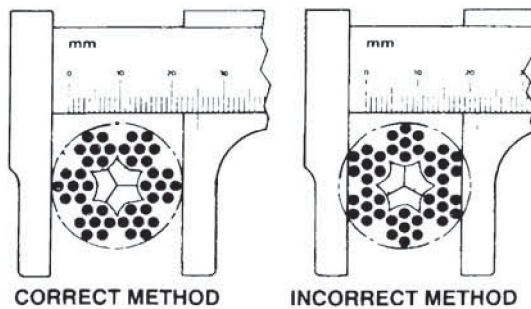

External wear on the individual wires is caused by friction on drums and sheaves.

Where the rope diameter has reduced to 85 per cent or less of the original diameter, the rope should be discarded even if there are no broken wires.

Fibre rope cores can be crushed and broken if the rope is bent over sheaves while the core is frozen. Under these conditions the FSWR can eventually lose its shape with serious internal corrosion.

When first reeved up and put to work a wire will show considerable wear because it is 'bedding in' to the sheave and drum grooves. After bedding in the outer wires will slowly continue to wear and the wearing surface will increase, although on crane ropes the rate of wear will slow down. Consider condemning FSWR when wear on the individual wires starts to exceed one third of their original diameter.

Before re-roping a thorough inspection should be made of the whole sheave system with special attention given to the sheave and drum grooves. A sheave which has been damaged by a previous rope will seriously damage a new rope.

The anchorage should be inspected. One broken wire at an anchorage condemns the rope at that point.

Also check for:

- cracks
- chafing of wires
- worn pins
- worn clevises
- worn thimbles
- corrosion - rust
- crushed or jammed strands especially where the rope may have jumped off the sheave and jammed between the sheave and cheek plate

- wear on the outside wires when the individual outside wires are worn to more than one third of the original diameter
- bird caging in Lang's lay or non rotating ropes especially at the anchorage
- overloading which can usually be seen by the elongation of the lay. (A normal lay takes approximately 8 diameters for a complete spiral.)

Handling new rope

When a new rope is ordered it is essential that the manufacturer's recommendations regarding length, lay, construction and diameter are followed. If this is not done the life of the rope can be severely reduced.

Laying onto a drum

The new rope should be delivered on a spool. Set up a spool so that the rope runs from the top of the spool to the top of the drum, or from the bottom of the spool to the bottom of the drum.

If a new rope is delivered in a coil, a turntable should be rigged up to run the rope onto the drum. A coil of rope must not be laid on the ground and wound straight onto the drum otherwise there will be severe twisting and kinking of the rope.

Do not take rope off one side of a reel laid flat on the ground as a loop because a kink may be produced from each wrap of the rope taken.

The whole cross section of the rope must be held solid when bolting or securing hoist or luff ropes to winch drum anchorages. If a rope is not completely secured the inner strands can pull out leaving only the outer strands secured at the anchorage.

It is preferable to make some form of gripping mechanism to keep the rope tight as it is wound onto the drum. Two pieces of 100mm x 50mm timber bolted either side of the rope and secured to the head of the boom can be used. The bottom layers of the rope must be tightly and neatly laid onto the drum.

The bottom layers on multiple layered drums must be laid on correctly. If they are not, the lead rope will jam in between lower layers under a heavy load causing condemnable defects in a new rope.

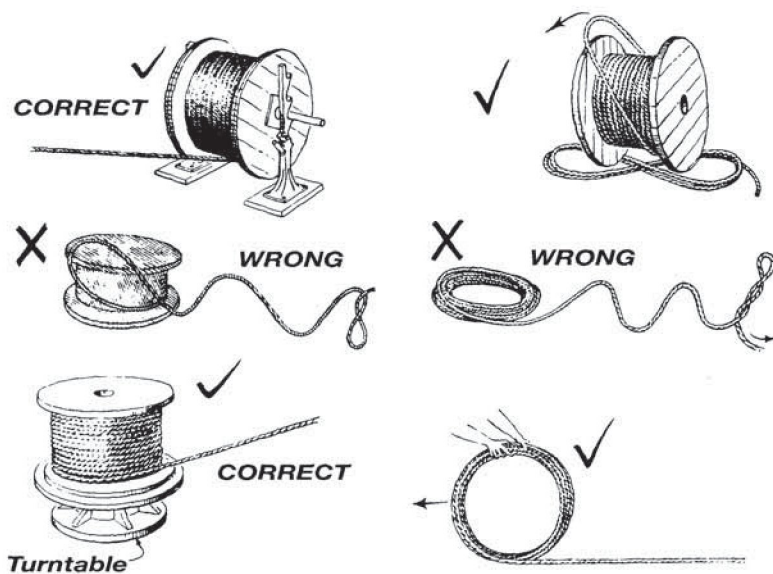

Wire rope: methods of uncoiling

When laying the rope onto an ungrooved drum, use a mallet or a piece of timber (to prevent damage to FSWR) to tap the turns together as they wind onto the drum to ensure that there are no gaps between the lays.

Manual uncoiling

If it is not possible to remove the rope from the reel by using jacks, stands, a turntable or by rolling the reel use the following procedure:

- with the reel resting on its flanges, unwind several wraps of rope to accumulate sufficient slack
- backup the rope to make a loose loop on the spool, slip one loop off the right flange and lie this loop on the floor
- slip a similar loop off the left flange and also lie it on the floor. The rope on the floor will then be in the form of a figure eight
- repeat this procedure first on the right, then on the left, until the required length has been unreeled
- roll the reel back off the accumulation of rope on the floor, and pull away the end of the rope. Watch out for any loops thrown out to prevent kinking.

Where the same situation exists with a coil of rope (eg where there is no turntable), the coil should be stood on edge and unrolled as previously described.

If as a last resort the rope must be laid on the ground and uncoiled, extra precautions must be taken to prevent kinking:

- the coil should be laid down so that the outside end of the rope finishes or spirals clockwise for right hand lay or anti-clockwise for left hand lay
- the stops or ties securing the coil may then be removed and the outside end carried along in a straight line, allowing the rope to revolve in the hands as the turns or loops are lifted carefully from the coil by another person and thrown or straightened out immediately as the rope is stretched along.

Rope that has been coiled with underturns by an experienced rigger, will pull away without kinking.

At all times care should be taken to prevent wire rope from running in sand, ashes, clinker, earth, mud and so on.

Hand splicing

A splice is a join in a rope or on to another rope by the interweaving of the separated strands of one part into another part, or into those of another rope.

For an eye splice made on the end of a rope, a short end of the rope is bent back on its own part to form the eye. The strands in the short end are separated, then secured into the main part of the rope by interweaving the strands into those of the main part.

Eye splices, short splices, and cut splices must be made by passing the strands over and under against the lay of the rope. Splices must be tightly drawn and neatly made.

Where a thimble or dead eye is inserted in an eye it must be a tight fit. To achieve a tight fit use a mild steel annealed strand 'flat' or 'round' seizing applied at the throat of the splice before beginning the splice.

Thimbles must be used where ropes are spliced to hooks, shackles, rings, swivels, pins, eyes, and similar fittings.

Hand splicing can only be learned under experienced supervision and with the correct materials. This section is designed to be referred to by those learning to hand splice.

Tools used for hand splicing

- at least two marlin spikes, sufficiently large for the rope being spliced, (one may be smaller than the main spike). They should have a knob at the butt end to grasp, be round for two thirds of the length before tapering gradually to a slightly oval section, and finish with a blunt chisel point at the tip.

The use of flat spikes with a flat T handle is not recommended as they can jar fingers or wrists if they slip after being turned at right angles. The chisel point and oval section of the spike described permit easier insertion, while the rounded section opens strands enough to tuck.

- wooden mallet or copper hammer.
- wire cutters and pliers.
- vice fixed to bench, preferably having grooved jaws.
- rope cutting machine, or cold chisel and a large hammer.
- a press for larger sized ropes instead of a vice. These have a right and left handed screw thread attached to brass jaws and are operated by a wheel. Jaws should be pointed for breaking thimbles into a rope and have flat caps to fit over when required for squeezing and seizing of ropes together.

Making a splice

Before commencing an eye splice whip the rope at the point where the splicing allowance of 1m for each 24mm has been made. Position the whipping level with the throat of the thimble and apply rope yarn or marline seizing to secure the rope to the thimble.

Bend the rope around the thimble and place it in a vice with the throat of the thimble above or at the end of the jaws. Screw the vice tight, being careful not to damage the rope (on small ropes lash a folded strip of canvas to the vice jaws).

Then drive a spike between the two parts of rope at the throat of the thimble.

This drives the thimble up and seats it tightly in the rope. Apply seizings to the throat and to the crown of the thimble (for large wires, use seizing wire).

If a flat throat seizing has to be applied, the rope around the thimble and for 12mm beyond the length of the seizing should have been served with tarred marline. The seizing is now put on by neatly tapping a thimble held in a vice.

Grip the rope in the vice ready to commence splicing. (Some splicers prefer to have the rope vertical and others prefer horizontal). The rope is now ready for splicing.

Remove the endbinding and unlay the short end of the rope to provide the tails for splicing, and remove the crutch seizing.

The fibre main core is tucked with tail number 1 for the first tuck. It is then cut off where it emerges from the main part.

Wire cores must never be cut from the rope. The core must be split up and the wires or strands distributed among the tucking tails then tucked with them for at least three tucks.

If the rope is not pre-formed it is advisable to whip the ends of each tail separately.

In all splices the spike must be entered as near as possible to the thimble or end fitting, and the tucking tail must enter into the portion of loop which is nearest the thimble or end fitting, ie under the spike. All tucks must be pulled down hard.

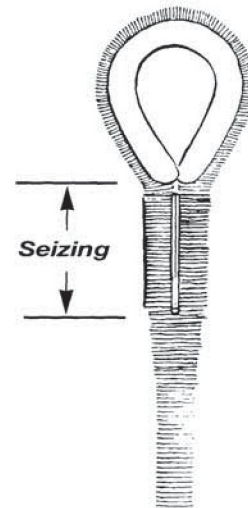

Throat seizing

To 'break out' wires when reducing the number of wires per strand, take each wire separately, snatch back to the point where it emerges from the rope and then twist the wire (handle fashion) reversing direction if necessary and the wire should part at the gusset.

Six strand rope - Five tuck splice

The inexperienced splicer should only learn firsthand from the expert splicer and use the description above as a guide. Only an experienced person can teach a novice the art of holding a spike, of taking a half a turn out of the strand end before inserting, the dipping of a tucked strand around the spike and so on.

The method described here is just one standard method of splicing. It is not possible here to describe all the splices, seizings and so on that are used. Use the steps below as a guide:

1. thimble in vice. Rope vertical. Main part of rope on right hand. Tail strands on left hand
2. thimble seized at crown and both flanks
3. the strands separated and the tails whipped at the ends
4. length of tails 100mm for each 3mm diameter of rope
5. for the first series of tucks a fibre main core should be tucked with Tail number 1 and then cut off. A wire main core must be split up, distributed among the tails, and tucked with them for at least three series
6. after the third series, the wires of a wire main core may be 'broken off' and the number of wires in each of the main tails reduced to half of the original number, preferably by 'breaking out'. The remaining wires must be twisted to a rough strand formation, and at the same time enclosing cut ends in the centre
7. remove the splice from the vice and hammer down the taper, starting from the eye end and working down the taper. This is to tighten up the tucks and to round up the taper. Remove the protruding wire ends, preferably by breaking them out, and again round up over the broken off ends. The taper or at least that portion containing the wire ends of the tails should be served with wire strand or spun yarn to give protection to the user when handling
8. each strand must be pulled down as tightly as possible. The tails should be pulled down in line with the centre of the thimble
9. to get the tuck tight and short, it should be beaten with a mallet or hammer. One object is to get the tuck as near as possible at right angles to the axis of the rope. Working the tucks with a mallet or hammer forces any slackness out of the tucking tails through the loop, and the beating should start on the position of the tail before its entry into the rope, and continue on the tuck itself. The strands of the main rope where they had lifted are beaten down to hold the tuck in place.

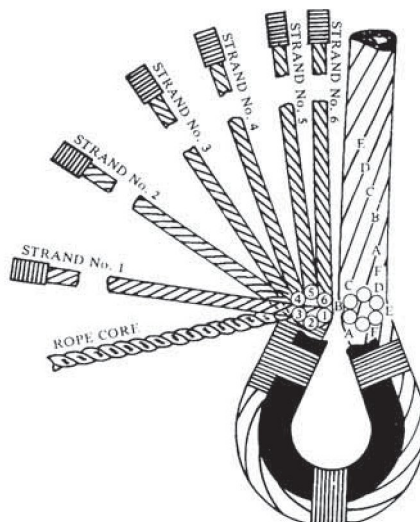

First Series		
Tail no.	In at	Out at
1	B	A
6 2	C	B
3 5	B	C
4	C	D
	DD	F
		E

Fourth Series		
Tail no.	In at	Out at
1	F	A
6	A	B
2	B	C
3 4	C	D
5	D	E
	E	F

Second Series		
Tail no.	In at	Out at
1	B	C
6 2	C	D
3	D	E
4	E	F
5	F	A
	A	B

Fifth Series		
Tail no.	In at	Out at
1	B	C
6 2	C	D
3	D	E
5	E	F
4	F	A
	A	B

Third Series		
Tail no.	In at	Out at
1	D	E
6 2	C	B
3	F	A
5	A	B
4	B	C
	C	D

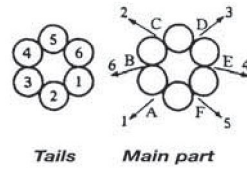
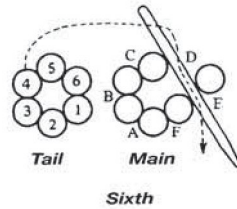
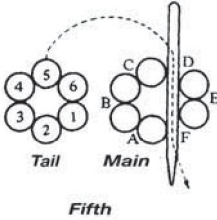
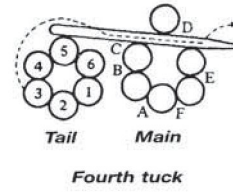
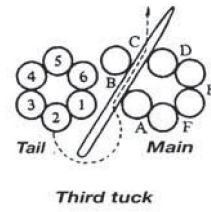
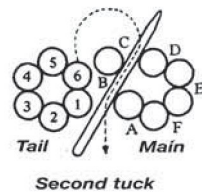
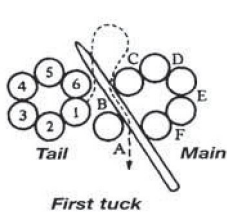

Serving

Splices in multiple strand ropes subject to constant handling should be properly parcelled and served with marline, spun yarn or annealed strand seizing wire, preferably for the full length of the splice, to the throat seizing to prevent laceration injuries.

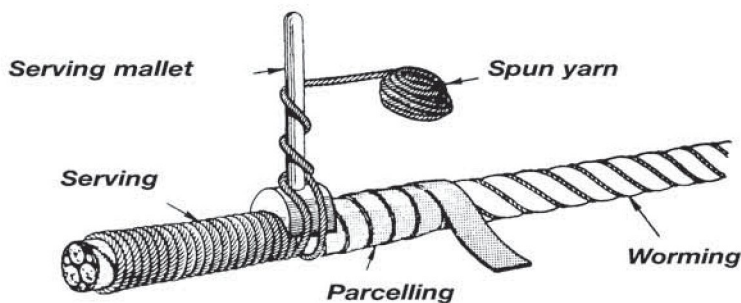

Slings and standing ropes

Slings and standing rigging ropes, up to 24mm diameter, must have at least three full tucks with each whole strand of rope and two alternative tucks, made by tucking alternative strands twice.

Over 24mm diameter and up to 32mm diameter there must be at least four tucks and two alternative tucks.

Ropes over 32mm diameter must have at least four full tucks and two split, reduced, or tapered tucks made with all strands, with one half of the wires in the fifth tuck and one quarter of the wires in the sixth or final tuck.

Crane ropes

Crane ropes up to 24mm diameter must have at least four full tucks with each whole strand of rope, and two alternative tucks, made by tucking alternate strands twice.

Over 24mm diameter, there must be at least four full tucks and two split, reduced, or tapered tucks, with all strands, with one half of the wires in the fifth tuck and one quarter of the wires in the sixth or final tuck.

Lang's lay

Lang's lay ropes of all sizes must have at least six full tucks with each whole strand of rope and two split, reduced, or tapered tucks with all strands.

Chapter 2 Winches, sheaves and purchases for flexible steel wire rope

Sheaves

Sheaves lead the rope over the head of cranes and hoists and are used in pulley systems to gain a mechanical advantage.

Flare angle and groove depth

The groove depth of a sheave should not be less than 1.5 times the rope diameter. However if the rope is positively prevented from leaving the groove the minimum depth of the groove can be equal to the rope diameter.

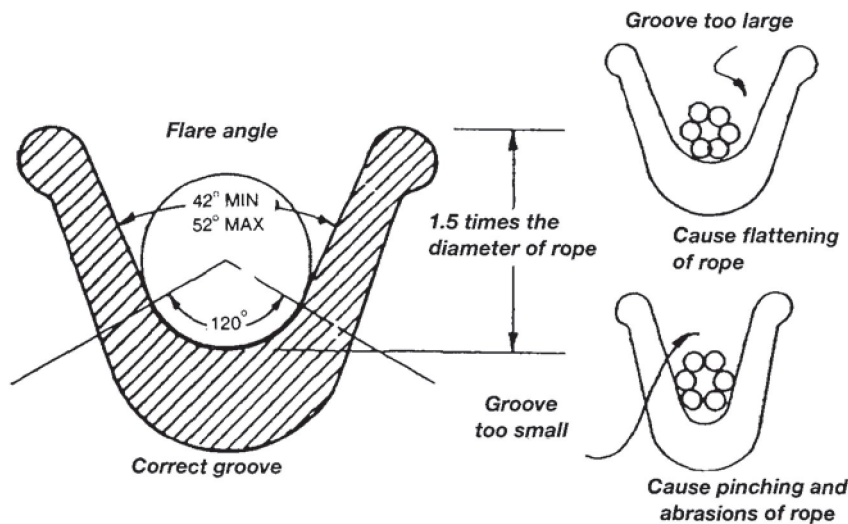

The sheave groove sides should have a flare angle of a minimum of 42° and a maximum of 52° .

The grooves should be slightly larger than the nominal diameter of the rope. Grooves which are too large will flatten the rope. Grooves too small will pinch the rope and the extra friction can cut it to pieces.

Sheaves should have a smooth finish with flared edges which are rounded off.

Sheave diameters

The table below gives sheave diameters and safety factors for types of work:

Duty	Classification	Type of work	Ratio to rope diameter			Safety factor	
			Drum	Sheave	Equaliser Sheave	Reeved	Other
Light duty	M1	Manual lifting with a chain block or 'one off' installations	11.2	12.5	11.2	3.15	2.5
Medium duty	M5	Normal use such as operation of a mobile crane	18.0	20.0	14.0	4.5	4.0
Heavy duty	M8	Continuous operation such as EOHT crane in steel prod. or a tower crane on building site.	25.0	28.0	18.0	9.0	5.0

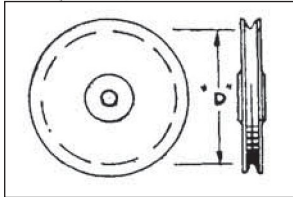

Caution: Modern cranes and hoists are complex engineering equipment, and many have special construction luff and hoist ropes. It is essential that the sheaves which were designed for a particular crane or hoist are used for that purpose.

It is also essential that when a rope is replaced, the replacement is the same diameter and construction and that the sheave system is thoroughly checked to ensure that any damaged or worn grooves likely to ruin the new rope are repaired or replaced.

Reeving

Large capacity cranes have several parts to the main hoist fall, making the main hook very slow.

When reducing the number of parts to give a faster hook ensure that the falls are not reduced from one side of the boom head sheaves and the main hoist block.

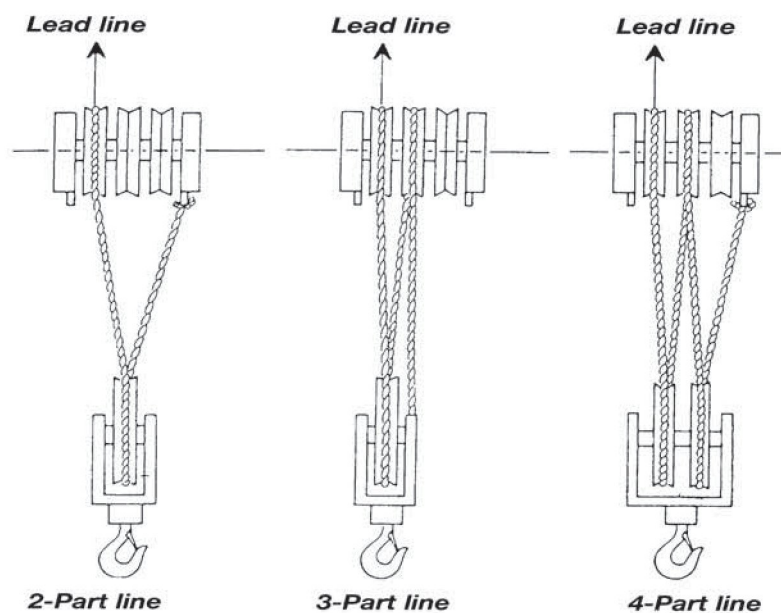

3 Sheave boom point

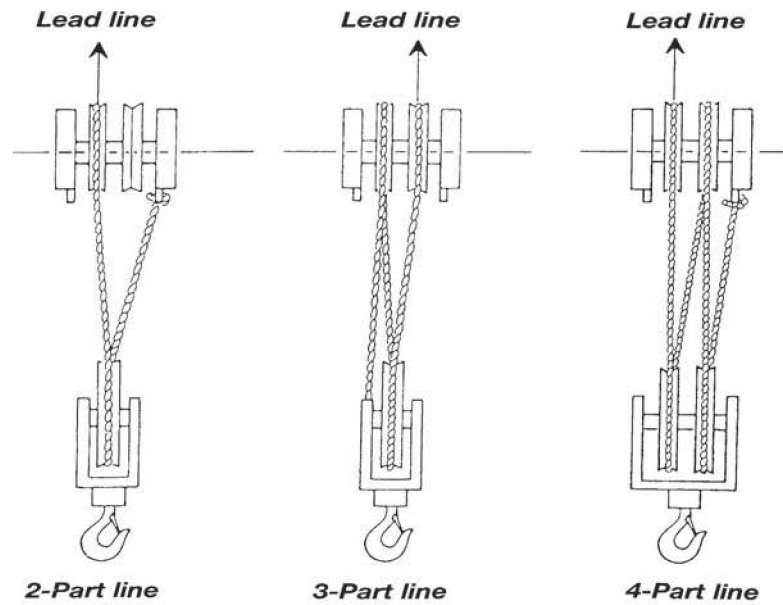

2 Sheave boom point

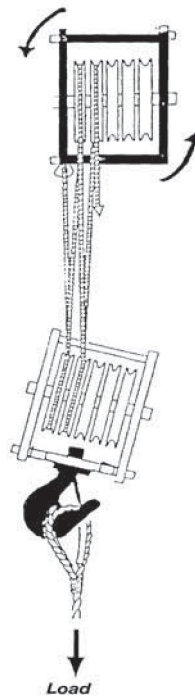

Unsymmetrically reeved blocks will tilt under heavy load.

Otherwise rotational torque can develop on the boom head exerting side pull on the main hoist block. When reducing parts the rope must be reeved again to ensure that there are an equal number of parts either side of the boom head and the main hoist block.

The number of parts must be capable of supporting the load to be lifted. A fast hook must still be a safe hook.

Inspection

Sheaves should be inspected regularly. Pay particular attention to the sheave groove and flange. Any cracks or chips on the flange can cut the rope as it lays into the groove.

The groove should be checked for wear that will result in the reduction of the groove diameter and give an uneven bearing surface for the rope.

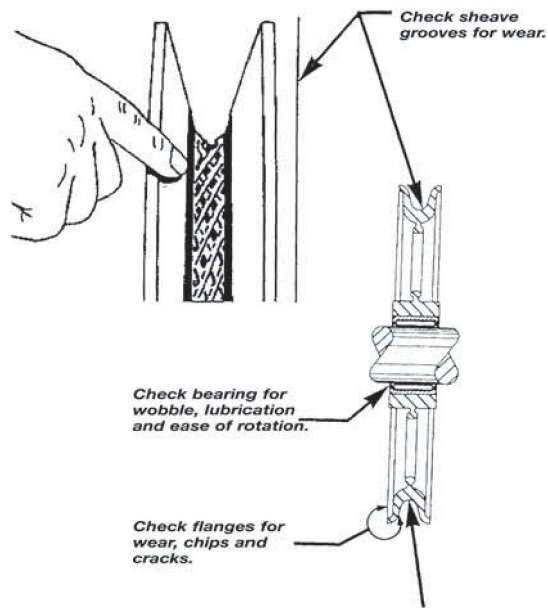

All sheaves should be checked for lubrication. Badly lubricated sheaves cause extra friction in the system and wear on the sheave pin and bearing.

The pin should be prevented from rotating with the sheave. Some sheave pins only have a small cotter pin which fits into a recess on the cheek plate. The cotter pin sometimes shears and allows the pin to turn with the sheave. Rotating pins are dangerous as they turn and can cut through the cheek plate.

A 'jockey sheave' is sometimes used as the first diverting sheave to reduce the fleet angle.

This sheave fits on an extended pin to allow it to slip from side to side reducing the fleet angle. The jockey sheave pin should be kept well greased and free from grit and dirt to allow the sheave to slide across the pin.

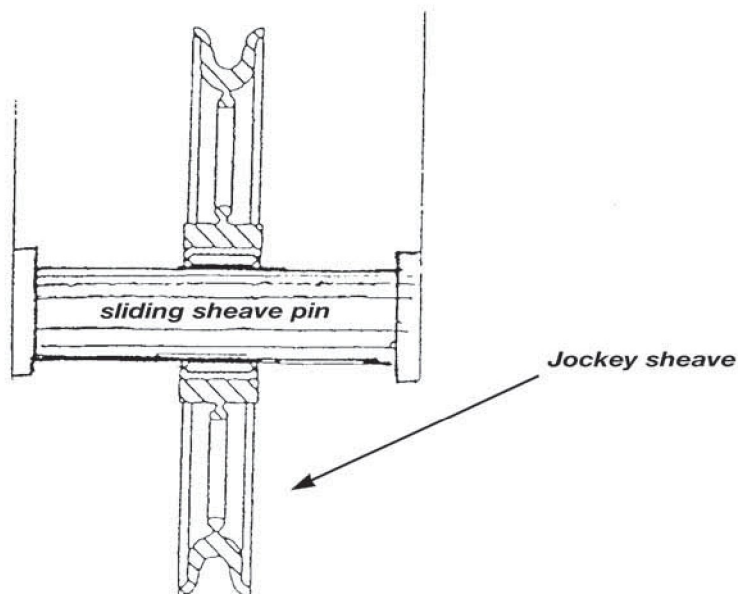

Drums

Drums are the pulling mechanism which rotates, hauls in and stores surplus wire. The braking mechanism is connected to either the drum or the gearing which is joined to the drive mechanism.

Drums are measured from the centre to the inside of the flange. A drum which measures 1m from flange to flange is therefore a 0.5m drum.

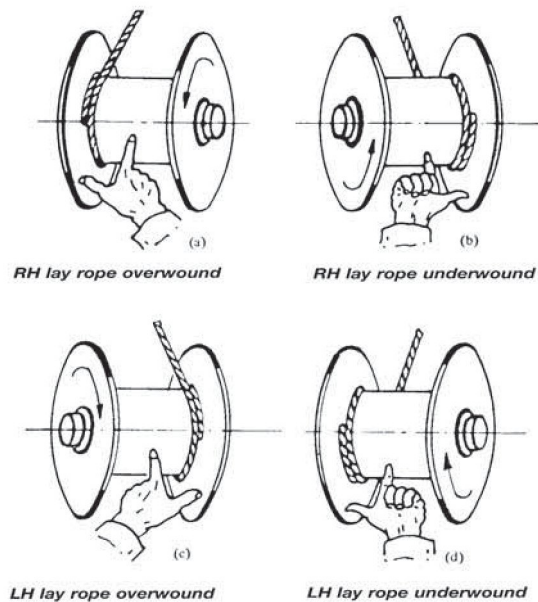

The rope should lay neatly on the drum and not be bunched up. There should be a minimum of two full turns on the drum at all times.

The rope must be anchored to the drum with a fixed mechanical anchorage. Be aware of the danger of not properly tightening an anchorage. Do not rely on the frictional grip relayed by the two turns on the drum.

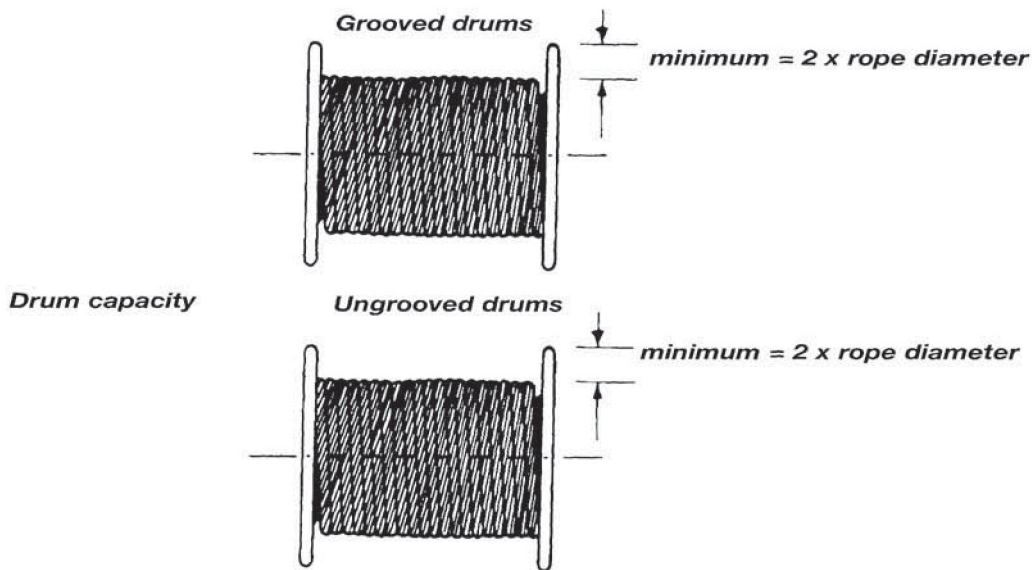

Comply with the crane manufacturer's recommendation about whether drums are overwound or underwound. If a drum is wound up incorrectly it can affect the anchorage, brake and drive mechanism to the drum, resulting in mechanical failure.

The lay of the rope and whether the drum is overwind or underwind determines where the rope is to be anchored.

Be especially careful when raising very heavy loads to a great height such as with long boom mobile cranes. The amount of turns on the drum determines the drum diameter. As the diameter increases the torque to the drive mechanism and brake increases. As a result the higher the load is raised the faster it is raised, and the more difficult the load is to control.

Operators should ensure that the hoist brake is adjusted to take the extra torque when the load is raised to its maximum height. A brake which holds the load near the ground may fail when the load is high.

The top layer on a multi-layered drum must not be closer than two rope diameters to the top of the flange when the drum is full.

Fleet angles

The maximum fleet angle is measured from the centre of the drum to the centre of the first diverting sheave then back to the inside flange at the middle of the drum.

The maximum fleet angle for a grooved drum is 5° and for an ungrooved drum is 3°. To achieve these angles the distance from the drum to the first diverting sheave must be a minimum of:

- 19 times half the width of the drum for an ungrooved drum
- 12 times half the width of the drum for a grooved drum.

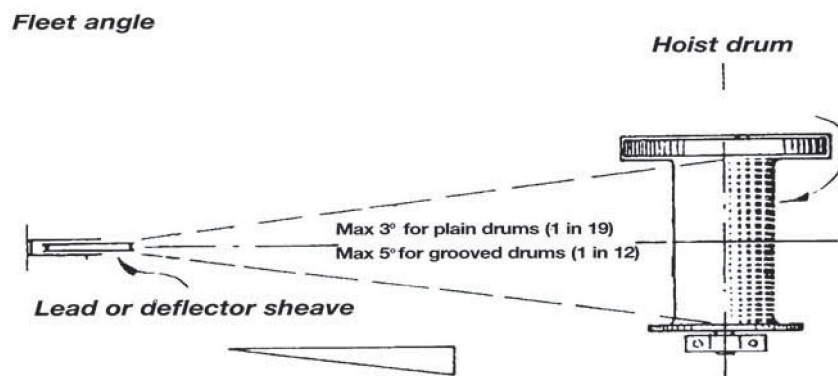

Example 1:

Width of the grooved drum = 1 metre

$$12 \times 1 \times 0.5 = 6$$

Therefore the sheave must be 6 metres from the drum.

Example 2:

Width of the ungrooved drum = 1 metre

$$19 \times 1 \times 0.5 = 9.5$$

Therefore the sheave must be 9.5 metres from the drum

If the fleet angle is too large or the distance between the drum and the first lead or diverting sheave is too short, the rope will not lay neatly on the drum and will create severe wear on the rope and the sheave flange.

When the fleet angle is too large

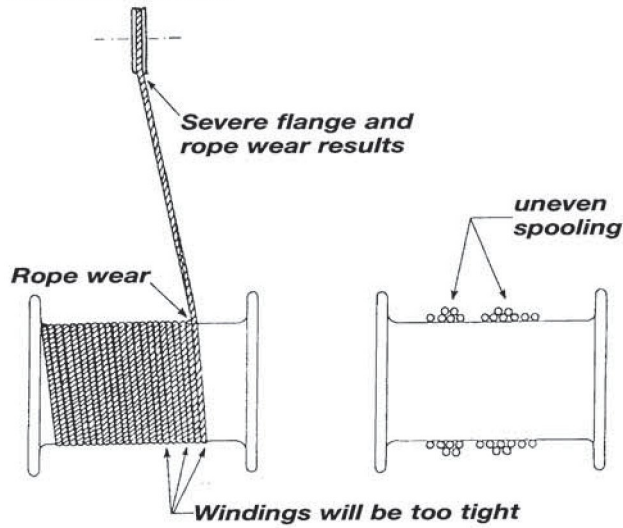

When the fleet angle is too small poor spooling results

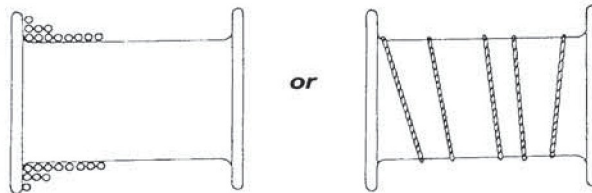

Effect of fleet angle on spooling

Safe loads on wire rope purchases

Use in connection with works of a temporary nature.

<p>The figures in each diagram indicate the number of running sheaves in each pulley block.</p> <p>Tabulated safe loads allow for one extra (lead) sheave (not shown in diagrams) and 5% friction in each sheave.</p> <p>LL = Load in the lead rope (as fixed by size of rope) – t</p> <p>D = Minimum diameter at bottom of groove of sheave – mm</p> <p>W = Safe load that may be lifted.</p>								
Rope size diameter	D	LL	Parts of rope supporting load – tonnes (friction 5%)					
			W					
mm	mm	t	1	2	3	4	5	6
8	120	0.58	0.53	1.01	1.45	1.86	2.23	2.58
10	150	0.9	0.82	1.57	2.25	2.88	3.46	4.00
12	180	1.3	1.18	2.26	3.25	4.16	5.00	5.78
13	195	1.5	1.36	2.61	3.75	4.80	5.77	6.67
14	210	1.8	1.64	3.13	4.50	5.76	6.92	8.00
16	240	2.3	2.09	4.00	5.75	7.36	8.85	10.22
20	300	3.6	3.27	6.26	9.00	11.52	13.85	16.00
22	330	4.3	3.91	7.48	10.75	13.76	16.54	19.11
24	360	5.2	4.73	9.04	13.00	16.64	20.00	23.11
28	420	7.0	6.36	12.17	17.50	22.40	26.92	31.11
32	480	9.2	8.36	16.00	23.00	29.44	35.38	40.89

Note: The above masses must not exceed those marked on the blocks as being the safe mass that may be lifted. Most blocks are limited by the size of hooks and other components and not the number of falls of rope. A factor for friction has been added.

- the safe masses shown in this table are for rope of 6 x 24 construction.
- the working load limit together with any conditions of loading deemed necessary for safe use is to be stamped or otherwise marked on each block.
- sheave diameters measured at the bottom of the groove may be as follows (temporary use only):
- For power operated blocks: 15 x rope diameter
- For hand operated blocks: 10 x rope diameter
- the beackets of blocks should be steel, preferably of drop forged or wrought construction. If welded they should be to an engineered design and strongly made.
- the locking pins of hook nuts, where used, should be closely adjacent to the nut top surface.
- hook shank collars should not be welded without an engineered design.
- snatch blocks should incorporate a locking pin of positive type not requiring the use of any tool for its effective positioning. A drop nose pin used as a hinge pin is recommended and the locking device must be strongly made and suitable for the intended use of the block.
- formula for calculating the load in lead rope: $LL = BL + (BL \times \text{No Sheaves} \times \% \text{ Friction})$ better formula is below as usually know winch capacity.
- formula for calculating a particular load in lead rope: $BL = LL + (1 + \text{sum of (sheave} \times \% \text{ friction)})$ and can have different friction on each sheave if wanted.

Purchases

A wire rope reeved through sheaves to obtain a mechanical advantage is known in rigging as a 'purchase'.

Purchase and lead blocks should have the close fitting cheeks pattern, or be the dished type where the sheave is recessed into cheeks.

Self lubricating sheaves are recommended, but if reservoirs are used they should be filled periodically, and leathers and set screw washers checked for tightness.

Snatch blocks

Snatch blocks can be dangerous and should always be carefully watched. The gate must be properly closed and the split pin inserted and split open.

As the winch takes the weight, lead blocks stand up and lay into the strain. As snatch blocks stand up the split pin must be facing down and must be spread. There have been many fatal accidents because the split pin has been inserted face up and then dropped out, the gate opening allowing the hoist rope to drop out of the sheave.

The eyebolt and shackle type of block is preferable to the hook type. If the hook type is used it is important that the hook is placed into the sling with the hook facing down. If the hook faces up, it can drop out of the eye of the sling as the winch takes the strain. The hook must be properly moused to the sling.

Sheave blocks

Sheave blocks should be pulled apart, inspected and greased before each new set-up with particular attention given to the pin. If sheaves are not properly greased, friction increases dramatically through the system as the load is raised. This can overload the hoist rope at the winch.

Ensure that all cotters, nuts and bolts are tight. Lead blocks should be supported at the becket to prevent the block from twisting. Twisting would cause the rope to jam or ride on the rim of the sheave, and slip between the sheave and the cheek plate, jamming and destroying the rope.

The anchorage at the standing part of a purchase must be made at the becket at the bottom of the top block. If the becket is defective the eye of the standing part should be shackled to the head sling of the top block. Do not secure the end to the upper eye or shackle of the top block because the rope may cut where it passes over the cheek plate.

The screw pins of 'D' or bow shackles should be moused where used on standing rigging, and running rigging where the pin can become unscrewed, causing a serious accident.

When lifting loads by bridle or cock billing, make sure that lifting slings are 'stopped' and packing and lagging is lashed on. Head slings must not render or slip during fleeting operations.

The lead from the head block of any purchase must not foul its own block or any part of a structure. Head slings must be prevented from slipping by a 'stopper' lashing. Prevention from slipping must be against the pull from the load in the lead or from any fleeting action.

Where any fleeting action takes place the load must be kept as low as possible to the ground or any supporting structure.

During fleeting do not stand in the line of pull from either set of blocks. Many people have been seriously injured because they were in the way of a surging load.

Timber packing or dunnage should be used if slings are likely to jam when landing a load.

How to work out the load in a single part of a purchase

The greatest load on any rope in a purchase is the load in the lead rope to the winch. This is due to the friction between the rope in the groove of the sheave and the sheave pin. Friction is estimated at between 3 per cent and 5 per cent per sheave (ie up to one twentieth of the rope load that would occur if there was no friction).

The effects of friction, acceleration or deceleration are not usually included when dealing with work of a temporary nature unless a number of falls are used or the rope velocity is high, ie. 0.6m/sec.

When a load is at rest, suspended from the lower block, the becket load (the load in each part of the rope purchase) is found as follows:

$$\text{Becket load} = \text{Total load on lower block} \div \text{No. of parts of rope supporting load}$$

Note: The total load on the lower block includes the load to be lifted plus packings, slings, shackles, blocks etc.

For example - (including frictional effects)

Total load on the lower block = 10t including gear

Number of parts of rope = 5 supporting the moving block

$$\text{Becket load (BL)} = 10 \div 5 = 2t$$

However as lifting commences friction causes the load in the rope falls to increase by up to 5 per cent for each sheave the rope passes over, including lead sheaves (if any).

The load in the lead to the winch (given 5 per cent friction) may be calculated as follows:

$$\text{Load in lead to winch (LL)} = \text{BL} + (\text{BL} \times \text{number of sheaves} \times 0.05) = \text{BL} + (\text{BL} \times \text{number of sheaves} \div 100)$$

or for a given load in the lead, the maximum load that can be lifted is calculated as:

Load = LL x no. of parts supporting load

1t (number of sheaves x friction)

Example 1:

No. of sheaves in purchase = 5 (3 top block + 2 bottom block) Number of parts of rope = 5 supporting lower block
Number of lead blocks = 2 (7 sheaves in total) Total load on lower block = 10t Becket load = 10 ÷ 5 = 2t
Load in lead rope to winch = 2 + (2 x 7 ÷ 20) = 2.7t

Example 2:

Calculate maximum load for the above arrangement using a winch with a 2.7t line pull Load =
2.7 x 5 = 13.5
1 + (7 x 0.05) = 1.35
= 10t

The above calculations do not allow for sudden impact, acceleration and deceleration which can cause very high loads in the rope. These should all be avoided.

Where the angle in a lead rope is less than 90 degrees, the strain on the lead block is double the strain on the lead rope.

If the lead block is shackled to, or hooked into a sling which is reeved, the sling has to have a capacity which is four times the load in the lead rope.

Reverse bends

Avoid reverse bends because they cause much greater fatigue than if all bends were made in the one direction.

A rope running in one direction over one sheave and then in a reverse direction (ie 'S' fashion) over another sheave will suffer early fatigue and deterioration. As the rope passes over a sheave it is bent, and as it leaves the sheave it is straightened, two distinct actions causing fatigue. This is made worse if the rope after being bent in one direction is then straightened, and again bent in an entirely opposite direction over another sheave after which it is again straightened.

Multiple layers on drums

If a load is to be lifted to a height where multiple layers must be layed onto a drum, there are several safety precautions that should be taken.

Independent steel wire cored ropes should be used to prevent crushing. Do not use 6/37 construction ropes because the small wires will suffer badly from crushing.

The drum must have the capacity to take the amount of rope. The bottom layers must be tightly and neatly laid onto the drum.

In the absence of any test certificate it must be assumed that the rope is made from 1570 MPa and the safe working load should be calculated accordingly.

The capacity of drums and storage reels

There is a rule of thumb formula for determining the amount of rope that can be stored on a storage reel. This formula can be used when determining whether the winch drum has sufficient capacity to take the amount of rope needed in a purchase.

Length of rope that can be stored on a reel Capacity L in metres = (A + D) x A x C ÷ 1000 x K

L = Length

A = Depth of reel flange in mm

D = Diameter of reel in mm

C = Distance between flanges in mm

K = A multiplying factor for various rope diameters (see table)

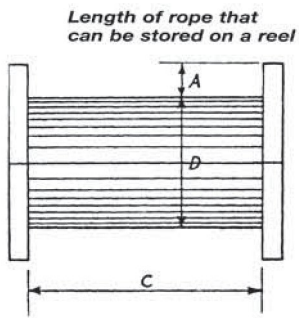

Rope storage reels

Rope diameter in mm	Multiplier 'K'	Rope diameter in mm	Multiplier 'K'
6	11.2	36	400
10	31	40	500
12	45	44	600
16	80	48	720
20	125	52	840
24	180	56	980
28	240	60	1120
32	315	-	-

Length of rope that can be stored on a drum

While a storage reel can be filled to the top of the flange a drum must not – 2 x rope diameters must be left from the top layer of rope to the top of the flange.

For drums A = Depth of reel flange in mm – 2 x rope diameter.

Purchase or tackle block?

Riggers must know the difference between wire rope purchase blocks and fibre rope tackle blocks. A fibre rope may be used in a purchase block but a wire rope must not be used in a tackle block.

A fibre rope tackle block would be greatly overloaded if used for the WLL of a wire rope of the same size. The difference between the two types of blocks is:

- the depth of the groove in a fibre rope tackle block should be not less than half the diameter of the rope used
- the depth of the groove in a wire rope purchase block must not be less than 1.5 times the diameter of the rope used
- the diameter of a fibre rope block is much less than that of a wire rope block for the same size rope
- pins and beackets are heavier and stronger in wire rope blocks.

Cable pulling stockings

Cable pulling stockings are used for reeving wire ropes through purchases and for fitting cables in various places where the opening or access is restricted.

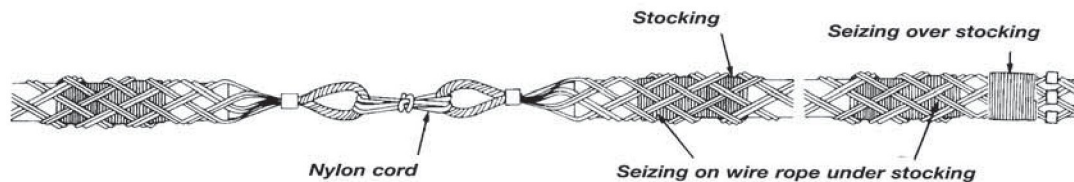

They are especially useful where the boom head, luff drum, and hoist winch of tower cranes are high above the ground.

A fibre rope is reeved and attached to the drum, and then is attached to the rope which is fitted with a cable pulling stocking. The rope is then pulled through the system by the fibre rope.

Cable pulling stockings must not be used for load lifting purposes.

Method for replacing an old rope

1. Cut the eye splice or metal clamp from the end of the old wire rope in the crane.
2. Remove grease from the cut end of the old wire rope for a distance of approximately one metre. Also remove grease from the new wire rope for a similar distance.
3. Slide one cable pulling stocking on to the end of the crane wire rope. Place a short seizing on the wire rope (using a mallet) so that it is under the cable pulling stocking about 50mm from the stocking end caps. Place a second secure seizing, using a stout cord or copper strand around the end of the stocking between the first seizing and the stocking end caps.
4. Repeat step three with the second cable pulling stocking on the end of the new wire rope.
5. Join the eyes of both cable pulling stockings with a sufficient number of turns of nylon cord which is then securely tied. The use of nylon lacing to connect the two stockings lessens the likelihood of snagging at sheaves and other points where clearance is at a minimum.
6. The winch of the crane then hauls the new wire rope into the crane. When the join of the new and old rope reaches the winding drum, the new rope is disconnected from the old rope and anchored temporarily to a suitable part of the adjacent structure. The old rope is then removed from the drum and then the new rope is anchored to the drum and wound on. Cable pulling stockings allow the rope joint to pass smoothly around the sheaves.

Chapter 3 Natural fibre rope and slings

Introduction

Fibre rope, also known as cordage, is used extensively for taglines, whips, tackles, lashings, and snotters for general lifting.

Natural or vegetable fibre ropes are grouped into those made from hard fibres and those made from soft fibres.

Hard fibre ropes are manila, sisal, coir and phormium tenax. Manila and sisal ropes are the main vegetable fibre ropes used for lifting in Australia. Coir is used where flotation is required and so is mainly used for boating.

Soft fibre ropes are jute, flax, hemp, and cotton. The fibres in these ropes are finer and very flexible and are used for ornamental purposes. They are often spun into twines or string for shop or household purposes.

Construction

The sequence of rope construction:

- fibres are combed into slivers
- slivers are twisted into yarns
- yarns are twisted into strands
- strands are twisted into the finished rope.

Hawser laid rope

Plain or hawser laid rope is the rope used for most general purposes including lifting.



3-strand hawser laid

For right hand lay hawser rope a number of fibres are twisted into a right hand lay, or spiral (helix) into a yarn. A number of yarns are twisted in a left hand spiral into a strand. Three strands are then twisted in a right spiral into a right hand lay hawser laid rope. Left hand lay rope is laid up exactly the opposite.

The thickness of the rope depends on the number of fibres that are laid up into the yarn and then the number of yarns laid up into the strand. The opposite lay is put in to stop the rope from unlaying and pulling apart.

Marline

Marline is used extensively in rigging for seizings. Three or four yarns are spun together in an opposite spiral and tarred.

Shroud laid rope

Inspection shroud laid rope is a four strand rope with a centre fibre rope heart. It is used for the manufacture of cargo, safety or scrambling nets, and rope ladders where there would be two strands either side of the tuck. The sectional area of four strand rope is less than three strand rope of the same diameter and the centre heart has a smaller spiral than the outer strands.

Shroud laid rope is therefore much weaker than hawser laid rope of the same diameter and should not be used for load lifting.

Cable laid rope

Cable laid rope is three hawser laid ropes laid up in an opposite spiral. They are used where great stretch is needed. They were used extensively in the shipping industry as mooring lines.

Inspection

Natural fibre rope is made from dried vegetable fibres and is subject to many deteriorating factors.

The whole rope should be inspected in a good light. Look at and feel the rope along the entire length. Open and inspect the lay and the interior every metre.

Look for the following defects:

- *the effects of heat.* If the rope has been exposed to more than 65° C the rope could be brittle, charred, powdery or brown on the outside
- *sunrot.* The natural colour of the rope will turn to a dirty grey, the outside fibres will turn very brittle and the rope will be much lighter than normal
- *mildew.* Open the lay and smell the inside of the rope and examine it. A musty smell is a sign of mould/mildew. There may be no outside signs of mildew
- *effects of acid and other corrosives.* The outside will be faded yellow to brown colour and powdery
- *overloading.* The fibres will be shorter, the diameter will decrease and the lay will increase in length
- *overworked over sheaves.* When the lay is opened there will be fine powder in the centre of the rope. The powder is fine particles of the inside fibres worn and abraded away and locked inside
- *high stranding.* One strand standing out above the others. It can be caused by faulty splicing or whipping
- *kinks.* Fibre rope will kink especially if it is wet. The outer fibres will be broken in one spot. This defect can be very hard to detect
- *cuts.* Fibre rope snotters should not be reeved around loads with sharp edges. Cuts are easy to detect but can be avoided by packing sharp edges
- *defective splice.* The eye splice in snotters should be carefully inspected. There should be three full tucks against the lay. The inside of the splice should be checked to ensure that there is no wear or broken fibres.

Fibre ropes which have defects should either be destroyed or if the defect is localised such as a cut, the rope should be severed at that point.

Maintenance

To maintain ropes in good condition free from attacks by mould and bacteria:

- store new coils on dunnage in a well ventilated area
- coil handlines and snotters and store on large wooden pegs above the ground
- keep rope dry and stored out of direct sunlight and never in an airtight box
- store away from any heat source, such as steam pipes, flame, sparks from welding or oxy cutting etc
- store away from acids or other corrosives, such as ashes, clinker, coke, oils, grease, steam, batteries etc
- protect from falling or sharp objects

- keep vermin away from ropes. Natural fibre ropes are prone to attack from insects which thrive on cellulose. The most common are clothes moths, beetles, ants, termites, silverfish and cockroaches. A trapped rat will gnaw through a rope to escape but in general rats are not attracted to rope for food or for bedding
- store ropes away from grit, rust, sand, dirt or other abrasive substances
- protect from adverse effects of weather such as sunlight, (sunrot) and mildew, caused by storing wet rope away in a toolbox or other area where there is no breeze to dry it out.

Handling

When a new coil of rope is delivered to the site it is covered with hessian bagging. Do not remove the cover. The coil is also tied with twine to keep it together.

If there is a turntable to uncoil the rope it can be unwrapped and lengths cut as required.

Do not remove the hessian covering if there is no turntable. The best way to uncoil the rope is from the inside. Turn the coil so that the loose end is on the bottom. Cut the inside holding twine and pull the loose end out through the top of the coil. The rope will then be uncoiled left handed.

A rope that is uncoiled right handed will uncoil full of kinks and twists. If this happens, turn the coil over and push the loose end back through the centre and start again.

To remove kinks and twists re-coil the rope left handed or anti-clockwise on a piece of dunnage dipping the end through and under the coil and then re-coil. This may have to be repeated two or three times before all twists are removed (reverse for a left hand lay rope).

Do not disturb frozen rope until it has completely thawed because frozen fibres can be easily damaged when handled.

Factors for assessing the capacity of fibre rope

For safe use as lifelines, slinging and general lifting gear in factories and workshops where not subject to rough usage, the working load limit (WLL) is the guaranteed breaking strain (GBS) divided by six.

Do not use fibre rope of less than 12mm diameter for load carrying purposes.

Fibre rope hauled by hand under load must not be less than 16mm diameter.

Fibre rope must not be subject to heat greater than 65°C.

Rope which has been shock or impact loaded or stretched by overloading must not be used for load carrying purposes.

The included angle between the legs of a sling attachment should not exceed 120° .

Whipping

Whippings are put on the end of a rope to prevent the rope from unlaying. They are made by using waxed twine or rope yarn. The length of the whipping should be at least equal to the diameter of the rope.

Whippings are preferable to back splicing on the ends of tackle falls because they will pass through the blocks when reeving the tackle. A second whipping should be applied nine rope diameters from the end for permanent whippings.

Types of whipping:

- the 'Common' whipping is used to prevent the rope unlaying while measuring or splicing
- the 'West-Countrymans' whipping and 'American' whipping are alternatives to the 'Common'
- the 'Palm and Needle' whipping is difficult to apply and is usually only made when a permanent whipping is required.

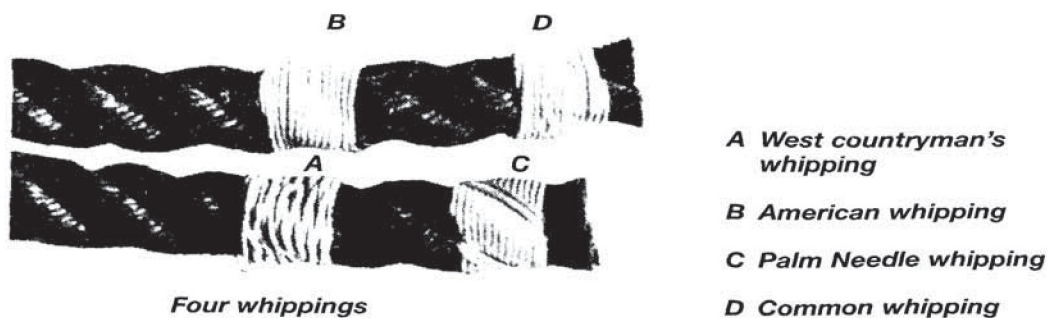

Seizings

Seizings are used to bind or seize two or more ropes together. They are made with machine cord, light mackerel or cod line. The four types are flat, round, square, and racking seizings.

The racking seizing is applied after a thimble is inserted, to seize the two parts together before making an eye splice.

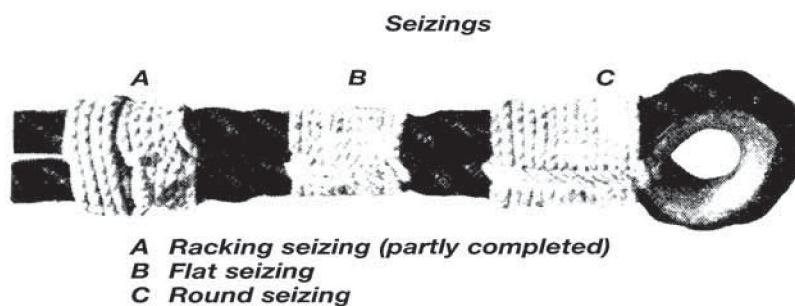

Worming, parcelling and serving

Worming is the process of laying lengths of spun yarn into the valleys between the strands of a rope to fill them and make the rope completely circular.

Parcelling is the process of wrapping strips of hessian, light duck (calico) or canvas around the rope or finished splice to give protection.

Serving is the process of binding over parcelling with a continuous length of seizing wire, marline or spun yarn. This is tightly laid on with a serving mallet. The rule is: worm and parcel with the lay, turn and serve the other way.

Splicing

Types of splices:

- *eye splice*. Can be either bald or with a thimble inserted. A fibre rope with an eye spliced either end for use in slinging is called a snotter
- *cut splice*. For joining two ropes leaving a loop between the splices
- *short splice*. For joining two ropes, or for joining two ends of a rope to make an endless rope strop

- *long splice*. For joining two ropes where the rope passes around a sheave. It should not be used where the rope supports loads or people. It may be used safely where a jockey, pilot, or dummy gantline is required to reeve off a FSWR purchase or similar use. **Caution:** It is possible for the tucked ends to come unlaidd in use
- *back splice*. For preventing the end of a rope from unlaying. Back splicing is used when whipping twine cannot be found. Do not use if the rope has to be reeved into a tackle because the splice is too thick to pass through the sheaves. It is made by tying a crown knot then two or three tucks against the lay.

The short, cut, and eye splices can be used for suspending loads or people, but cannot pass through the sheave cheek plates. They should have at least three full tucks against the lay. After the three full tucks the ends of the strands can be reduced and tapered and the splice served.

However when a load is applied to the rope and the splice stretches, the serving will become loose. It is better, stronger, and safer to dog knot half the strands with a neat seizing after completing the splice.

Thimbles

A thimble should be spliced into the eye of the standing or becket eye of a tackle. Thimbles are solid round, split round or pear shaped split. They are split to enable them to be opened and fitted to the anchorage and then closed before splicing.

There should be no points on the throat of the thimble that could bite into the rope. Thimbles should be large enough to allow the rope to seat well into the score with the rope supported for half of its circumference without the groove edges biting into the rope. A small thimble can cut the rope and do more damage than ordinary wear and abrasion.

Fibre rope slings

Grommets

A grommet is an endless loop of fibre rope similar to a strop. It is formed by laying up a single strand. The length of the strand needed must be at least three and a half times the circumference of the finished grommet. The strand must be married at the required diameter then laid up until it is a three stranded loop. The ends are then halved, overhand knotted, tucked and then reduced.

Strops

A strop is where the two ends of a piece of rope are spliced with a short splice making an endless sling. They are called strops whether they are made of FSWR or fibre rope.

They are used as tackles, whips, lashings, snotters, and general lifting gear where the rope is liable to rough usage. The WLL is the GBS divided by seven.

Snotters

A snotter is a fibre rope sling with eyes spliced into each end. The eyes of snotters should be properly spliced by a competent person with three full tucks against the lay. Snotters should not be reeved or choke hitched around sharp edges unless proper packing is used to protect the fibre rope. Snotters are used where FSWR slings or chains would damage a load or where the use of metal slings could be dangerous. They are seldom used on construction sites and should not be used where the loads are lifted overhead.

Blocks and tackles

A tackle is the term used when fibre rope is reeved around sheaves to gain a mechanical advantage. **Caution:** Fibre rope tackle blocks must not be used for FSWR purchases.

Blocks

Blocks are made of wood (clump), wood and steel (internal iron bound IIB), and steel. The wooden clump blocks are fitted with a FSWR or fibre rope stop fitting in a score at right angles to the sheave and steel pin. The sheaves are usually bronze or gunmetal. Some older sheaves were made from the very hard wood, called lignum vitae.

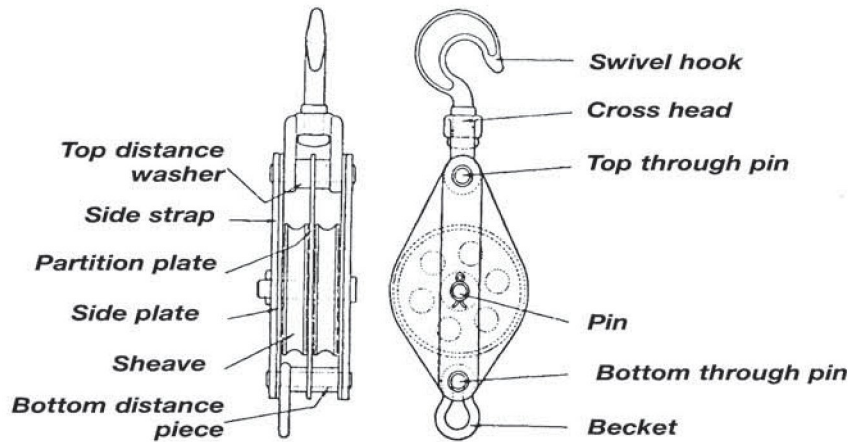

Double sheave block

The wooden IIB block has beech cheeks and partitions, with a forged eyebolt and forked steel plates morticed into the cheeks and drilled to take a steel pin. The sheaves are usually bronze or gunmetal and the pin is secured by a steel keeper plate over a square head.

Steel blocks are made of mild steel cheek plates secured to a yoke drilled for an eyebolt or a forged hook. Reinforcing plates often run down outside the cheek plates to the bottom, where they are drilled to take becket, spreader bolts and ferrules.

The sheave pin fits into holes drilled through straps, cheeks and partitions and is usually of mild steel with a flanged end and a spigot with a cotter retainer at the other end. Lifting hooks or eyes are the swivel type (not upset or riveted type).

Care must be taken when maintaining and inspecting to look for worn pins, sheave bushes, insecure fastening of the hook yoke to cheeks and yoke crosshead, securing of sheave pin, becket and pin and general soundness of the whole frame.

Types of tackles:

- gantline – a single fixed block
- single whip – two single blocks
- whip upon whip – two moveable and one fixed single block
- luff tackle – single and double block
- gun tackle – two double blocks
- light gin tackle – or handy billy – double and treble blocks
- heavy gin tackle – two treble blocks.

Safe loads on natural fibre rope blocks

Use in connection with works of a temporary nature when hand operated.

<p>The figures in each diagram indicate the number of running sheaves in each pulley block.</p> <p>Tabulated safe loads allow for one extra (lead) sheave (not shown in diagrams).</p> <p>P = Pull in the lead rope (as fixed by size of rope) – t</p> <p>D = Minimum diameter at bottom of groove of sheave – mm</p> <p>W = Safe load that may be lifted.</p>								
Rope size diameter	D	P	Parts of rope supporting load – tonnes					
			W					
mm	mm	kg or t	1	2	3	4	5	6
16	80	0.29	0.28	0.53	0.76	0.97	1.16	1.34
20	100	0.49	0.44	0.84	1.20	1.53	1.84	2.12
24	120	0.66	0.63	1.20	1.72	2.20	2.64	3.05
28	140	0.88	0.84	1.60	2.30	2.93	3.52	4.06
32	160	1.10	1.05	2.00	2.87	3.67	4.40	5.08

Note:

The above masses must not exceed those marked on the blocks as being the safe mass that may be lifted. Most blocks are limited by the size of hooks and other components and not the number of falls of rope. A factor for friction has been added.

- The safe masses shown in this table are for natural fibre rope – 3 strand hawser laid.
- The working load limit together with any conditions of loading deemed necessary for safe use is to be stamped or otherwise marked on each block.
- Sheave diameters measured at the bottom of the groove may be as follows (temporary use only):
- For power operated blocks: 10 x rope diameter
- For hand operated blocks: 5 x rope diameter
- The becketts of blocks should be steel, preferably of drop forged or wrought construction. If welded they should be to an engineered design and strongly made.
- The locking pins of hook nuts, where used, should be closely adjacent to the nut top surface.
- Hook shank collars should not be welded without an engineered design.
- Snatch blocks should incorporate a locking pin of positive type not requiring the use of any tool for its effective positioning. A drop nose pin used as a hinge pin is recommended and the locking device must be strongly made and suitable for the intended use of the block.
- Fibre rope should not be less than 16mm diameter when held under load by hand.

Sheaves

The diameters of sheaves used with fibre ropes must be at least five times the diameter of the rope when hand operated. For power operated appliances the sheave diameter must be at least ten times the rope diameter.

The sheave diameter is measured from the bottom of the groove. If a rope sits too tightly in the bottom of the groove it can become damaged when wet or swollen. The depth of the groove should be at least half the rope diameter.

Reeving

A tackle for right hand laid rope must be reeved right handed (clockwise from left to right) starting from the bottom. Lay the blocks down with the becket at the top and finish the reeve with a splice or a buntline hitch at the becket.

Tackles when rove should be left block against block with a tail rope for overhauling on the lower block. As the tackle is overhauled the fall rope should be kept free of turns allowing the tackle to run free of turns and twists.

When tackles are rove off left handed and turns are not shaken out of the running end, the tackle will spin full of twists. A lower block which has toppled will cause turns and twists so care should be taken to dip the lower block back in the correct direction.

Guys and lifelines

Do not use fibre rope for permanent guys. Natural fibre rope shrinks when wet and stretches when dry. Do not leave temporary fibre rope guys supporting or guying an object overnight. Use FSWR as guys wherever possible.

Where fibre rope is used for lifelines, make sure that a back hitch or clove hitch is used at every support point to prevent slackness. They should be tightened and inspected regularly. When rove through stanchions a thimble and lanyard should be provided at one or both ends and always kept tightened to prevent the line from slipping through if anyone leans on it.

Do not use fibre rope where there is a danger of combustion from sources such as welding or oxy cutting.

Frapping or bowsing lashing

A frapping or bowsing lashing is a short lashing used to pass several turns through a thimble or shackle in order to pull a wire rope tighter. It should consist of a number of turns, pulled tight and given a chance to equalise in an outsize thimble or shackle. The lashing may be further tightened by half hitches pulled tight around the several parts. A stack or mast frapping is when a rope is passed around a stack and secured to a boatswain's chair to prevent the chair from swinging away from the work.

Bends and hitches

Riggers must know how to secure loads and tag lines with bends and hitches. Learn those described and illustrated below.

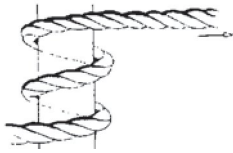

Rolling hitch - To secure stopper, or two ropes pulling in opposite directions. Very useful - preferable to clove hitch or blackwall hitch, providing rolling turns are put on in proper direction of pull. Safe.

Timber and half hitch
- useful for hoisting lengths of timber. Only safe additional half turns on end of timber. Snubber turns for holding of when and lowering heavy loads. three or more should be used.

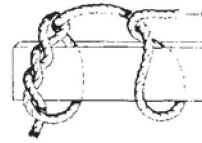

unless ends secured, with additional half-hitch.

Bowline single - used for making temporary eye in end of rope.

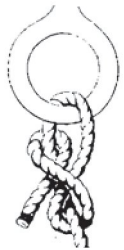
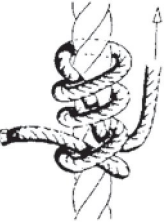

Buntline or becket hitch - to secure ends of tackles to becket. Foolproof; cannot come undone like half hitches.



Bowline running - used for making a temporary eye to run along another part of rope.



Sheet bend - to join two dry ropes of different sizes. Safer when double sheet bend is used. The smaller rope must be bent around the larger rope.



(i) Bowline on the bight.



Double sheet bend.



(ii) Bowline on the bight.

Fisherman's bend and half hitch - useful for bending rope onto rings, handles of buckets, etc - requires the extra half hitch.

Clove hitch - used to commence rope lashing. Not safe for other purposes

Shortener for single part



rope or snorter - to join rope to hook of tackle, etc and does not damage the rope. At least two full turns of the standing part are to nip the two bights before the bights are placed on the hook.

(iii) **Bowline on the bight** - the bowline on the bight is formed by making the first part of a bowline with the bight of the rope and passing the whole hitch through its bight.

Overhand knot - to make a



Single snorter shortener stop on a made. Two bights ends from ready to be placed on hook. prevent



rope, to prevent partly fraying or to it slipping through a block.

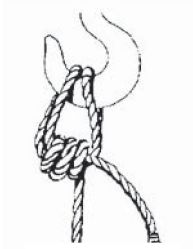

Figure of eight knot - as for an easier to untie. Single snorter shortener with both bights fitted on hook.



overhand knot, but



Round turn and two half hitches - widely used for securing running ends of tackles. The more turns made before hitches are made the more control is possible.

Double shortener - each of the two parts of the bale sling or strop is turned back on itself, so that two bights are formed at a suitable length. The bights are then turned about each other as in a simple overhand knot and place on the hook.

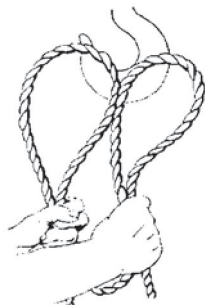

Double shortener for sling on hook. better method for

Direction of pull on spike



Marlin spike hitch - should not be used for sending tools or materials aloft. A tools is to open up the rope and push tool through.

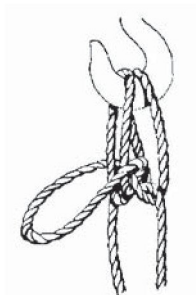

Double shortener for sling partly made.

NB When shortening synthetic rope slings it is usually advisable to twist the bights twice about each other because of the slippery nature of many synthetic ropes.

Chapter 4 Synthetic fibre rope and slings

Introduction

Synthetic fibre ropes are generally made from filaments twisted into yarns, the yarns twisted into a strand then three strands into the rope similar to natural fibre ropes. A filament is one long continuous fibre which can continue for the whole length of the rope. Synthetic fibre rope should conform to AS 4142 Fibre-rope.

Natural fibre ropes rely on the friction of twisting to stop them from pulling apart. Synthetic ropes can be much thinner and yet have a greater WLL than natural fibre rope because they do not have overlapping fibres and because some filaments are stronger than natural fibres of the same thickness.

Each type of synthetic fibre rope is subject to different deteriorating and condemning factors. Some are affected by acids while others are affected by alkalis and most are difficult to tell apart after some use. All types have different strengths and so the WLL is not constant.

Synthetic fibre ropes have a smooth slippery surface which can cause slip and failure of most bends and hitches and are not suitable for hand haulage. Prevent this with additional half hitches or seize the tail with yarn, twine or marline.

Where splices are made, two additional (five) tucks with all of the strands are made and the protruding strands halved and fused together to prevent the splice from drawing or pulling out. All plain ends of rope should be whipped, to hold the strands together until the rope is fused.

Under some conditions synthetic fibre rope can conduct electricity and therefore should not be used as taglines near powerlines.

Types of synthetic fibre rope

Nylon (Polyamide filament)

Nylon has a breaking strength 2.25 times the breaking strength of natural fibre rope. It is not resistant to all chemicals and can be affected by linseed oil and mineral acids such as sulfuric and muriatic acid. Alkalis have little effect.

Heat resistance is higher (250°C) than natural fibre rope, which begins to char at 150°C. Although nylon melts or fuses with excessive heat it stops smouldering when the heat source is removed. It can melt with the heat build up when turns are surged around warping drums.

Nylon has about four times more stretch than natural fibre ropes which is good for shock loads but has little value for lifting gear. It is resistant to rot and mildew.

Dacron-terylene (Polyester filament)

Dacron-terylene has twice the breaking strength of natural fibre rope and is not as elastic as nylon. Resistance to mild acid conditions, rot, mildew, heat or flame are the same as nylon. Exposure to alkaline conditions (eg caustic soda) should be avoided.

Taniklon (Polyethylene filament)

Advantages of synthetic fibre rope Inspection Tankilon has about 1.45 times the breaking strength of natural fibre rope. (Similar features to Terylene).

Kuralon (Polyvinyl alcohol)

Kuralon has about 1.25 times the breaking strength of natural fibre rope. (Similar features to Terylene.)

Silver rope (Flat spin taniklon fibre)

Silver rope has about 1.16 times the breaking strength of natural fibre rope. Thirty per cent lighter than natural fibre rope or nylon. Does not absorb moisture and does not slip as easily as taniklon or other synthetics.

Polypropylene (Laid shattered film type)

Polypropylene has about 1.6 times the breaking strength of natural fibre rope. It is unaffected by water and will float. It is also unaffected by acids or alkalis except in a very concentrated form. Its strength is reduced by heat (15 to 30 per cent loss of strength at 65°C).

Advantages of synthetic fibre rope

Synthetic fibre ropes have many advantages over natural fibre ropes including:

- greater strength size for size
- lighter weight size for size
- greater elasticity or stretch
- greater shock absorption because of greater elasticity
- greater resistance to rot and mildew
- better resistance to abrasion
- some are resistant to acids, others to alkalis
- greater flexibility, ease of handling
- less water absorption.

Inspection

The whole length of synthetic fibre ropes should be inspected for signs of defects that may make the rope fail and therefore condemn the rope. Manufacturers' information and advice on inspection should be followed.

Conditions and tools for inspecting rope properly:

- a 300mm length of rope for comparison that was cut from the end of the line at the time of purchase
- enough room to handle the whole length of the line systematically
- a good light
- a magnifying glass may be of assistance.

The entire length of the rope must be inspected at intervals of not more than 300mm. The rope strands should be unlaidd slightly to inspect the inside. Care should be taken to return them to their original position after inspection.

Look for:

- external wear due to dragging over rough surfaces which causes a general reduction of the crosssection of the strands. This is the most visible cause of weakness. The strands can become so worn that the outer surfaces are flattened and the yarns are severed on the outside. In ordinary use, some disarrangement or breakage of the outside fibres is unavoidable and harmless if not too extensive

- local abrasion as distinct from general wear. It may be caused by the passage of the rope over sharp edges while under tension and may cause serious loss of strength. It is usually intermittent in the form of tearing of the fibres, yarns or strands. Slight damage to outer fibres and an occasional torn yarn may be considered harmless, but serious reduction in one strand or less serious damage to more than one strand could merit rejection
- cuts and contusions from careless use may cause internal as well as external damage. They may be indicated by local rupturing or loosening of the yarns or strands
- internal wear caused by repeated flexing of the rope particularly when wet, and by particles of grit picked up. It is indicated by excessive looseness in the strands and yarns
- heavy loading may result in permanent stretching so that the extension available in an emergency is reduced. If the original length of the line is known exactly, a check measurement made under exactly the same conditions will indicate the total extension of the line, but may not reveal local extension in part of the line. Measurement of the distances between indelible markers on the line may help reveal local stretching. The local extension should not exceed 10 per cent for synthetic ropes. Immediately after severe loading causing permanent extension, a line may be unusually stiff although flexibility may return
- mildew does not attack synthetic fibre ropes
- sunlight – Excessive exposure to sunlight will weaken all synthetic fibres. Unnecessary exposure should be avoided. However, sunlight will degrade polyolefin fibres (polyethylene and polypropylene) more rapidly than others. Degradation is shown by breakage of the fibres into small pieces which gives a hairy appearance as a result of the broken fibres tending to stand up as they break down into a coarse powder.

These symptoms are more readily observed on polypropylene than on polyethylene ropes at similar stages of degradation. The effect extends progressively below the surface of the rope, but because it is primarily a surface effect, small ropes will become unserviceable and unsafe quicker than large ropes. Work to develop suitable protecting agents, pigments and ultraviolet absorbers has been in progress for some time. Carbon black at a concentration of at least one per cent has proved successful for prolonging life. Other compounds show promise and are still being evaluated.

- heat may, in extreme cases, cause charring, singeing or fusing which all merit rejection. **Caution:** A line may be damaged by heat without showing any obvious signs. The best safeguard is proper care of the line in use and storage. Never drag a line in front of a stove or other source of heat.

Synthetic fibre ropes and chemicals

If unsure about the effects of a chemical on a synthetic fibre rope check the Material Safety Data Sheet (MSDS) which should be available for all chemicals used or stored in the workplace.

Polyamide

Polyamide filament is generally resistant to chemicals but solutions of mineral or formic acids (used in insecticides and as solvents for perfumes) cause rapid weakening. Therefore, avoid any contact with acid solutions either hot or cold. Polyamide filament is unaffected by alkalis, such as bleach and detergents, at normal temperatures. It may swell in some organic solvents such as cleaning agents. Avoid exposure to fumes, spray or mist of acids. If contamination is suspected, wash out well in cold water.

Polyester

Polyester filament is generally resistant to chemicals although solutions of strong, hot alkalis progressively dissolve the fibre, causing gradual loss in mass and a corresponding fall in breaking strain. Therefore, avoid exposure to alkaline conditions.

Resistance to acid is good, particularly sulfuric acid, although concentration should not exceed 80 per cent. Therefore, even dilute solutions of sulfuric acid should not be allowed to dry off on a rope. If any contamination is suspected, the rope should be washed out well in cold water. Resistance to oils and common organic solvents is good.

Polyethylene

Polyethylene ropes are highly resistant to chemical attack from both acids, such as battery acid, and alkalis. At room temperature the chemicals which cause serious loss in strength are some oxidising agents eg hydrogen peroxide. At 60°C there is also a loss in strength caused by some organic solvents such as turpentine. If contamination with any of these substances is suspected, the rope should be washed out well in cold water.

Polypropylene

Polypropylene ropes are unaffected by acids or alkalis, but are attacked by organic solvents such as white spirit. Avoid rope contact with wet paint or coal tar or paint stripping preparations.

Flat webbing and round synthetic slings

Flat webbing and round synthetic slings are used for lifting where it is necessary to protect the load from damage and for protection from electrical hazards. They are made from nylon, polyester, polypropylene or aramid polyamide. Each sling must be labelled with the WLL.

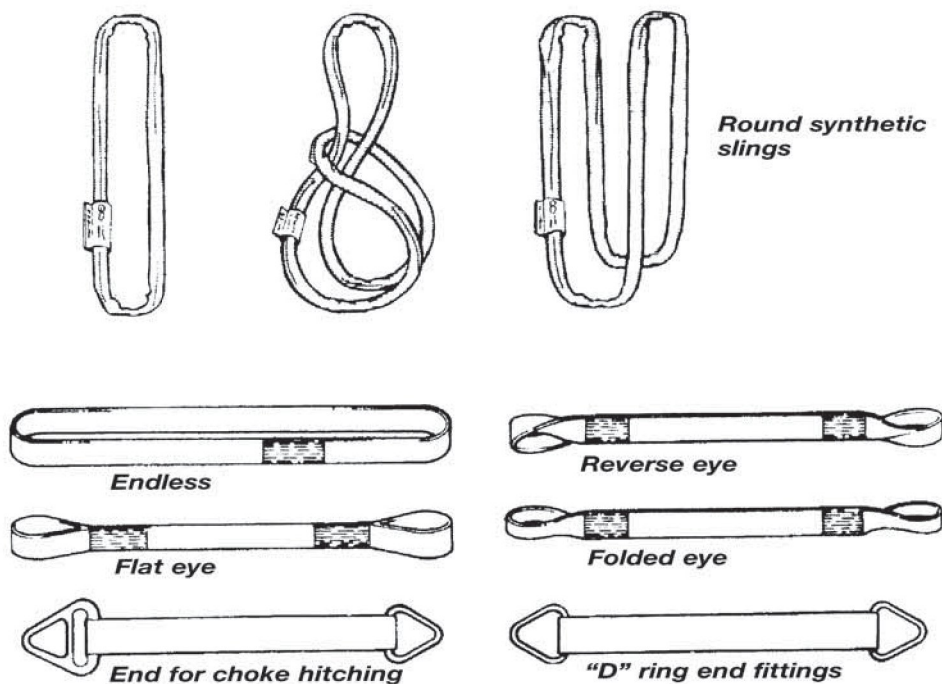

Types of synthetic slings and fittings

Inspection

Synthetic slings must be inspected before each use. They must also be inspected at least once every three months. If a sling is subject to severe conditions the inspections should be more frequent. Send each sling for a proof load test at least every 12 months.

Look for:

- any external wear such as abrasion or cuts and contusions

- internal wear which is often indicated by a thickening of the sling or the presence of grit and dirt
- damage to any protective coating of the sling
- damage caused by high temperatures, sunlight or chemicals (indicated by discolouration)
- damage to the label or stitching
- damage to the eyes or any terminal attachments or end fittings
- where the sling is covered by a sleeve, the sleeve must cover the sling for the full length from eye to eye.

Discard a synthetic sling if:

- the label has been removed or destroyed
- there is any damage to the sleeve or protective coating
- a nylon sling comes into contact with acid
- a polyester sling comes into contact with alkaline substances
- a polypropylene sling comes into contact with an organic solvent such as paint, coal tar or paint stripper
- there are any visible cuts on the sling.

NB: A nylon sling will lose more than 10 per cent of its strength when it is wet.

After six months continuous exposure to sunlight send a sling in for testing.

Synthetic slings must be stored:

- in a clean, dry, well ventilated place
- away from the ground or floor
- away from direct sunlight, ultra-violet light and fluorescent lights
- away from extremes of heat
- away from sources of ignition
- away from atmospheric or liquid chemicals
- away from the possibility of mechanical damage.

The working life of synthetic slings will be shortened if exposed to any of the above.



(a) Damaged sleeve
(a) Damaged sleeve

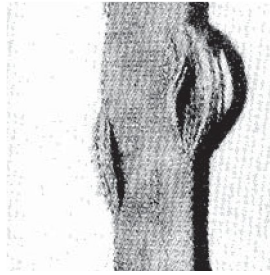

(b) Some damage to load-bearing
(b) Some damage to load bearing
fibres fibres



(c) Badly damaged sleeve
(d) Badly damaged sleeve

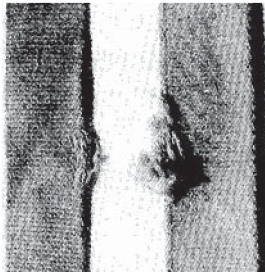

(d) Load-bearing fibres have been cut
(d) Load bearing fibres have been cut

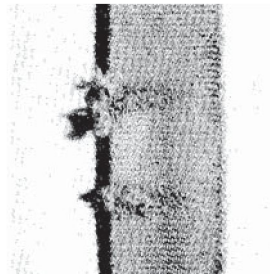

(e) Cut load-bearing fibres
(e) Cut load bearing fibres

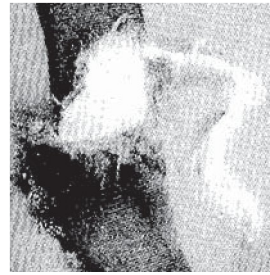

(f) Broken load-bearing yarn
(f) Broken load bearing yarn

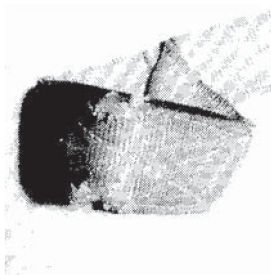

((g) The use of hooks that are too narrow has damaged the eye of the sling
(g) The use of hooks that are too narrow has damaged the eye of the sling



((h) Burn damage to sleeve and load-bearing yarn
(h) Burn damage to sleeve and bearing yarn
load-bearing yarn

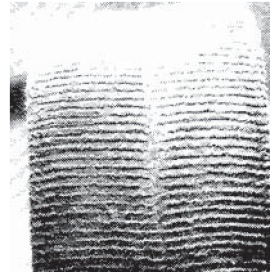

((i) Surface wear evident by furry surface
(i) Surface wear evident by furry surface
surface

Examples of extreme damage to flat synthetic-webbing slings.

Chapter 5 Chain

Riggers must have the knowledge and skills to recognise the types of chain used to safely lift loads and those which are not.

Lifting chain

Lifting chain is uncalibrated, proof tested, short link chain. The barrel of short link chain requires a greater force to bend, provides greater strength, reduces the tendency to twist and provides better reeving performance.

The outside length of the link does not exceed five times the diameter (of the link material) and the outside width does not exceed 3.5 times the diameter.

Lifting chain is produced on a special purpose automatic chainmaking machine to ensure uniformity and homogeneous welds. A continuous coil of carbon steel or alloy steel rod is fed into the machine which cuts and

bends the link around dies, then electrically welds the specially prepared join in the formed link. The weld is then trimmed by two methods:

- the welding flash is removed from the outside of the material leaving a tit of weld on the inside of the link
- the welding flash is completely trimmed from all round the weld area.

Grade designation is then stamped or embossed on the chain. In some cases every link is marked, but all lifting chain must show grade marking at least every metre or every 20 links, whichever is less.

Short link chain can also be calibrated to ensure uniform link pitch for running over a pocket sheave which is sometimes called a 'gypsy'. Calibrated chain gives a constant and uniform pitch throughout the length of the chain and improves its lay (it does not twist as much as uncalibrated chain).

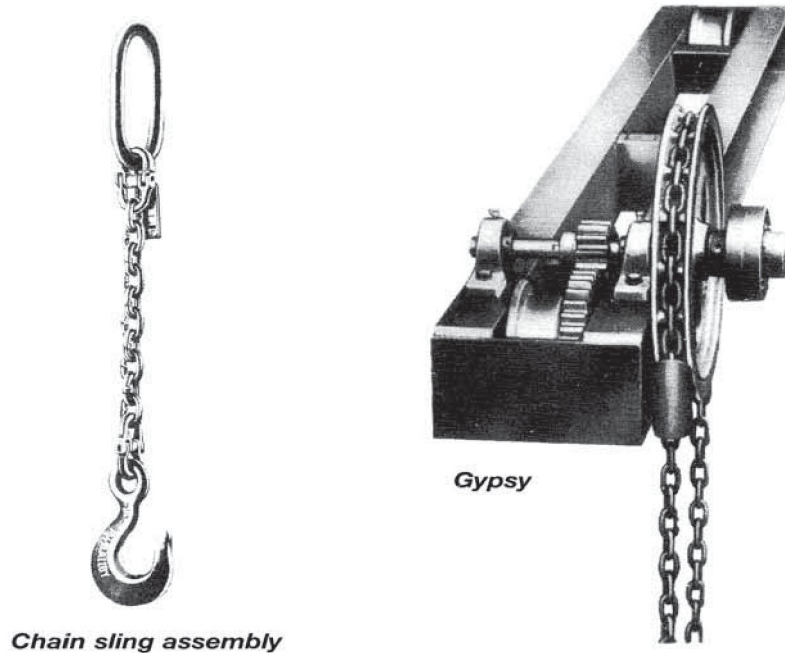

Gypsies are used to raise or lower the chain in a chain block. They can be driven by hand, pneumatically or electrically. Although most manufacturers today produce chain for chain blocks of similar size and shape, it is important to obtain replacement chain from the manufacturer of the chain block to ensure correct fit.

If the chain does not fit neatly into the gypsy it will jam, ride out of the wheel pockets, or suffer wear or link damage. If this occurs it could lead to premature failure of the chain, damage to the gypsy pockets and possible accidents from the chain riding out of the pockets under load.

Unpocketed sheaves and drums designed to take chain must be at least 24 times the diameter of the chain. Link length should not exceed 6 times the diameter and the width should not exceed 3.5 times the diameter. Welds must be smoothly finished and the diameter of the weld must not be less than the diameter of the material in the chain.

Types of lifting chain

- Mild steel stress relieved chain – stamped L.
- High tensile, quenched and tempered chain – stamped P.
- Higher tensile, quenched and tempered chain branded T, 8, 80, A, 800, PWB, or CM and HA800 alternately.
- Very high tensile, quenched and tempered chain branded 100, Vor 10.

High Tensile and Very High Tensile (Grade T. 80 and 100) are used extensively for lifting. Very little low grade chain is used for lifting. Most, if not all, chain components are also High Tensile strength (Grade T or 800) and are branded to show grade and chain size.

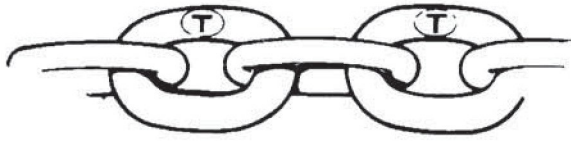

Look for the grade marking

If riggers do not understand the grade marking of a chain, they should check with the manufacturer or the manufacturer’s supplier for clarification.

Caution: Industrial lifting chain is not normally sold through general hardware outlets. Chain from general hardware outlets is usually unsuitable for industrial lifting.

MAXIMUM SAFE WORKING LOADS (SWL) IN TONNES OF 1000 KG													
Chain size mm	Single leg slings			21 3 or 4 slings						Endless slings			
	Straight sling	Adjustable sling	Reeved sling	Straight sling			Reeved sling			Basket sling		Reeved sling	
				60°	90°	120°	60°	90°	120°	60°	90°	120°	
6.0	1.2	1.2	0.95	2.2	1.7	1.2	1.6	1.3	0.95	1.6	1.3	0.95	1.9
7.1	1.6	1.6	1.2	2.8	2.3	1.6	2.1	1.7	1.2	2.1	1.7	1.2	2.4
8.0	2.0	2.0	1.5	3.5	2.9	2.0	2.6	2.1	1.5	2.6	2.1	1.5	3.0
10.0	3.2	3.2	2.4	5.5	4.5	3.2	4.1	3.4	2.4	4.1	3.4	2.4	4.8
13.0	5.4	5.4	4.0	9.4	7.6	5.4	7.0	5.7	4.0	7.0	5.7	4.0	8.1
16.0	8.0	8.0*	6.0	13.9	11.4	8.0	10.4	8.5	6.0	10.4	8.5	6.0	12.1
20.0	12.8	12.8*	9.6	22.2	18.1	12.8	16.6	13.6	9.6	16.6	13.6	9.6	19.2
22.0	15.8	11.8*	11.8	27.4	22.3	15.8	20.5	16.7	11.8	20.5	16.7	11.8	23.7
25.4	20.6	15.5*	15.5	35.8	29.2	20.6	26.8	21.9	15.5	26.8	21.9	15.5	31.0
31.7	32.2	24.2*	24.2	55.9	45.6	32.2	41.9	34.2	24.2	41.9	34.2	24.2	48.4

Safe working loads for slings of special alloy chain (Marked "C.M.", "A", "T" or 8).

Other types of chain:

- **Stud link chain.** A special purpose marine chain with a stud across the centre of each link to prevent the chain from jamming when coming out of ship’s chain lockers. Do not use for lifting.
Stud link chain lacks the flexibility of a lifting chain. Under test, it shows no elongation, whereas open link chain shows considerable elongation.
- **Bush roller chain.** Including Reynolds, Morse, and Coventry types. It is used as the drive chain on bicycles, motorcycles or the load chain on fork lift trucks. It has no sideways flexibility, so should not be used for suspending loads unless the load is in between guides.
- **Proof coil chain.** Is not made for load supporting. It is used as load binder chains, skid chains, hand chain on chain blocks, or general purposes other than load lifting. Proof coil chain is usually not branded and not made to any standard. It is not made for lifting purposes and should not be used as lifting chain.
- **Grade 65** is a high tensile load binder chain and is branded ‘65’. It is not a lifting chain and should not be used for lifting.
- **Grade 70/75** is a high tensile load binder chain and is branded 70, 7, HI-FRT, or HiLITE and is sometimes supplied gold coloured plating. It is not a lifting chain and should not be used for lifting.

- **Long link chain** is made in various grades from mild steel to Grade 80 and is used on conveyors, as ship cargo chain and for lashing. It is not a lifting chain and should not be used for lifting.

Inspection of chain

To prepare for inspection, clean the chain thoroughly, and lay it out in a good light on a table. Use a magnifying lens with a built-in light and examine every link. If the chain is made up into a sling, examine all of the parts of the sling assembly and look for the following defects:

1. **Stretching.** Stretched links are a sign of overloading. Chain should be condemned if links show obvious signs of any stretching.

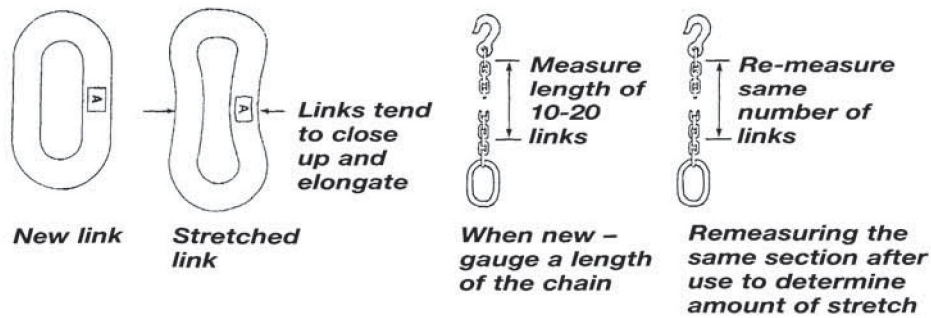

Look for chain stretch during inspections

High tensile Grade T, Grade 100 and Grade 800 chain has been proof tested to 2.3 times its working load during manufacture. If chain has stretched in use it has been loaded more than 2.3 times its working load. Grade T, Grade 100 and Grade 800 chain only stretches a significant amount as it approaches its breaking strength, so stretched chain should never be used.

Oblong links or rings have been proof tested to twice the working load and stretching indicates overloading. If oblong links or rings have stretched more than 5 per cent, they should be scrapped.

Chain hooks have also been proof loaded to twice their working load prior to supply, so if the hook has opened it is a sign of overloading or incorrect use. Hooks which have opened more than 5 per cent should be scrapped.

2. **Bent links.** Links can be bent by reeving chain around square objects which are not properly packed. If the chain is bent at the link weld, the chain should be inspected very closely to ensure that the weld has not begun to fail.

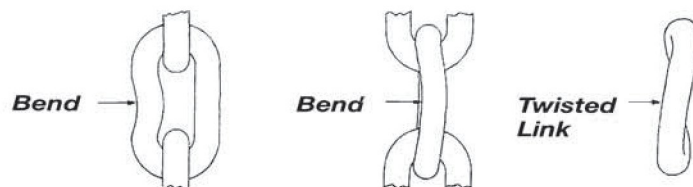

Inspect all links for bends, twists and damage

3. **Damaged links.** Reeving around sharp edges without proper packing will gouge the chain link. Dragging chain along workshop floors can wear chain. Chain which is worn, nicked, cut or gouged to a point where the metal in the link diameter is reduced by 10 per cent or more should be condemned.
4. **Rust.** Most chains will develop discolouration meaning some surface rust. This should not be confused with deep rust which will make the chain unsafe to use.

5. **Cracks.** To find cracks soak the chain in a light oil, wipe dry and apply a coating of powdered chalk or whiting to the surface. Leave for several hours and then examine. If a crack exists, the chalk will draw up the oil from the crack and become discoloured, showing up the shape of the crack. There are also special preparations available which can be used for showing up or locating cracks.

6. **Wear.** Where links seat on each other they wear. This wear is most prevalent in load chain in chain blocks. When the chain passes over the gypsy the links are subject to extreme friction. The links wear very quickly if the chain block is being worked continuously near maximum loading.

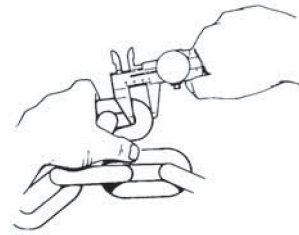

Measure the links to check for wear

If the tension cannot be released from the chain it should be checked for wear. Caliper across two links and divide by two to obtain the diameter. Then check this against an unworn part of the link. The chain must be replaced if wear exceeds 10 per cent of the diameter.

7. Inspection records of slings and sling leg lengths should be commenced when chain is new and maintained to give a reference check. The length of used sling legs may be greater than their original length due to wear, but caution should be taken to ensure no stretching has occurred.

Care and maintenance of chain

- do not overload chain
- do not use a chain with locked or stretched links or which has links that do not have free movement
- do not hammer a chain to straighten a link or force a link into position
- do not use an excessively pitted, corroded, unduly worn, deformed, chipped, nicked, cracked, or otherwise damaged chain
- do not snatch or jerk loads being handled by chain slings, especially in cold weather. Sudden lifting can have the effect of doubling the load in the sling. Chain and chain slings should not be used in temperatures below -20°C as this extreme cold could make chain brittle
- do not cross, twist, kink or knot chain
- do not drag a chain by force from under a load
- do not drop a chain from a height
- do not roll loads over a chain
- do not use a chain over sharp edges without proper packing on the edges. Hessian bagging is not good enough. Use cut lengths of rubber car tyre, half rounds of tube or timber. All packing should be secured when sending loads aloft. When the load is landed the slings go slack and the packing can drop out
- do not use lifting chain at temperatures over 400°C without consulting the manufacturer. Lifting chain used at temperatures over 200°C requires derating. Refer to table for the reduction factor

Temperature range ° C		Temporary reduction of WLL while heated
Up to 200		Nil
200 - 300		10 per cent
300 - 400	25 per cent	Over 400
		Do not use

- do not place the links of a chain so that they bear on the hook of a crane or hoist (except an endless chain sling)
- do not join chain by using a bolt or a bulldog grip
- do not shorten a chain by twisting or wrapping it around a hook
- when not in use all chain lifting gear should be stored on racks or pegs, under cover
- any screw thread used in connection with chain blocks must be securely locked
- the load chain of a chain block should not be used as a sling
- any repairs to chain should be referred back to the manufacturer or supplier
- chain links and load chains of chain blocks should be frequently inspected and lubricated between uses, or more frequently for repetitive lifts at near capacity
- do not use chain in corrosive environments without reference to the manufacturer.

Chain sling assembly

Chain slings should be made up to AS 3775 *Chain slings-Grade T* or the manufacturer's recommendations. When ordering parts for chain slings ensure that they comply with the appropriate Standard.

Avoid making up slings from different grades of chain or fittings. Try to use only one grade of chain throughout the workplace. This will prevent confusion about the WLL of slings for given diameter chain slings, especially if a WLL tag is missing.

Typical marking for metal tag

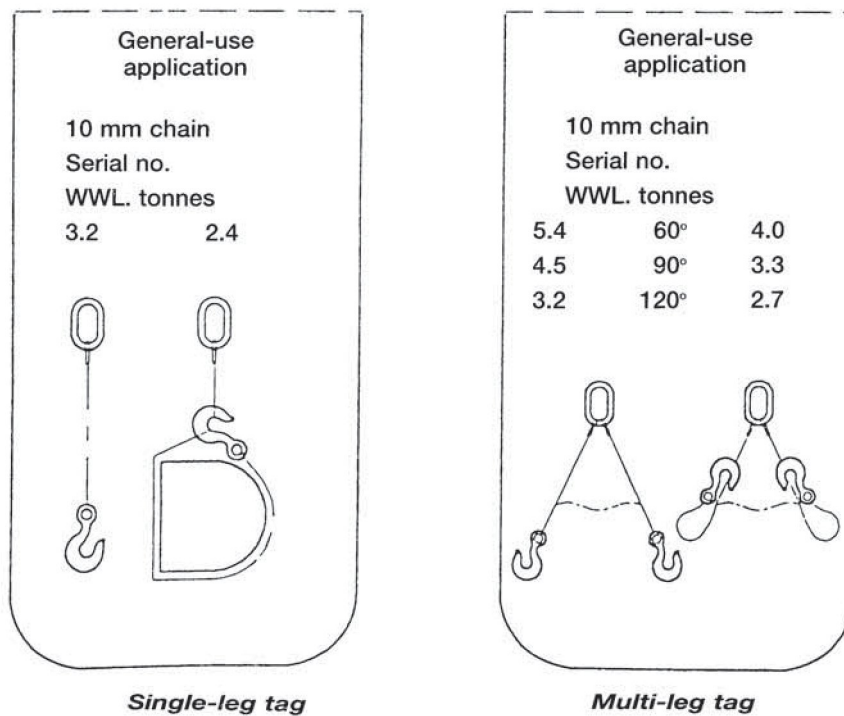

The chain, large oblong link, hammerlocks or couplers, and hook should all be of equal capacity or grade. Riggers should have the knowledge and expertise to inspect a chain sling to ensure that the grade and safe working load of all components match.

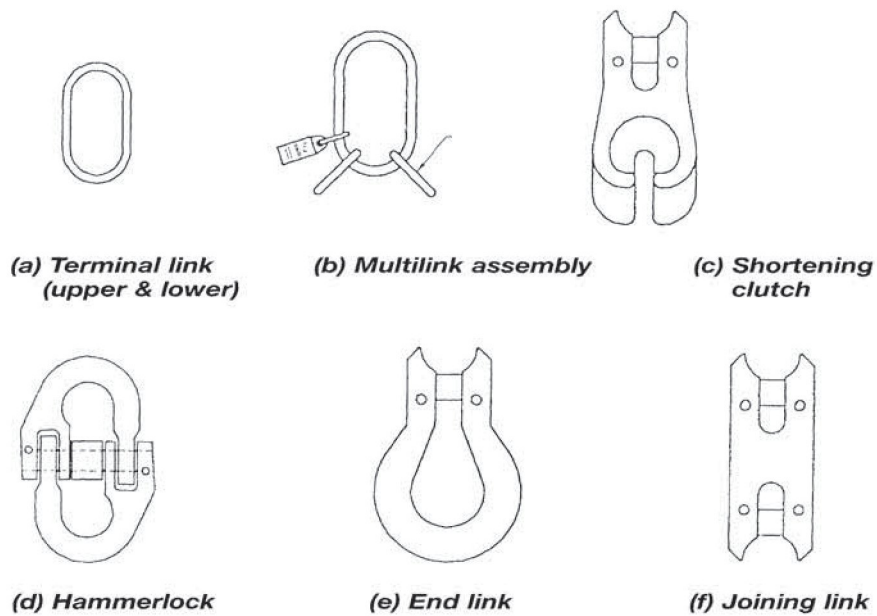

Chain sling links – various types

The working load limit tag must be fixed on all chain assemblies. The tag must detail the SWL under all conditions of loading.

If a tag is missing the sling should be taken out of service, unless the necessary information is marked on the master link. Once the tag is replaced the sling can immediately be returned to service. The tag should be replaced by a competent person.

Coupling links, often branded Hammerlok or Kuplex are used to connect alloy chain to alloy rings and hooks. Make sure that the pin connecting the two halves is firmly in position and that there are no cracks running from the inside corners of the forked part of the links.

Twist the spacer in the centre of the link to ensure that it is free. A jammed spacer is a sign that the chain has been overloaded.

Four leg chain slings should be fitted with two intermediate links on the main ring.

Rings

A ring must be strong enough to safely handle the WLL of all attached chains or slings.

Rings must be inspected frequently. Do not use a ring which has stretched more than 5 per cent of its mean diameter.

Do not place a ring on to a hook unless it hangs freely over the bow of the hook.

Chapter 6 Anchorages and fittings

Wedge rope sockets

Anchorages are used for securing standing and running gear such as attaching the wire rope to the drum, the head of the boom or the crane hook.

The eye on the anchorage for a non-moving rope (called a 'dead eye anchorage') must have a thimble. A splice with no thimble (called a 'bald eye splice') should not be used on an anchorage.

Wedge type rope socket anchorages are used extensively for cranes where the hoist fall is often re-reeved around the sheaves for extra purchase. These socket anchorages should comply with AS 2740 *Wedgetype sockets*.

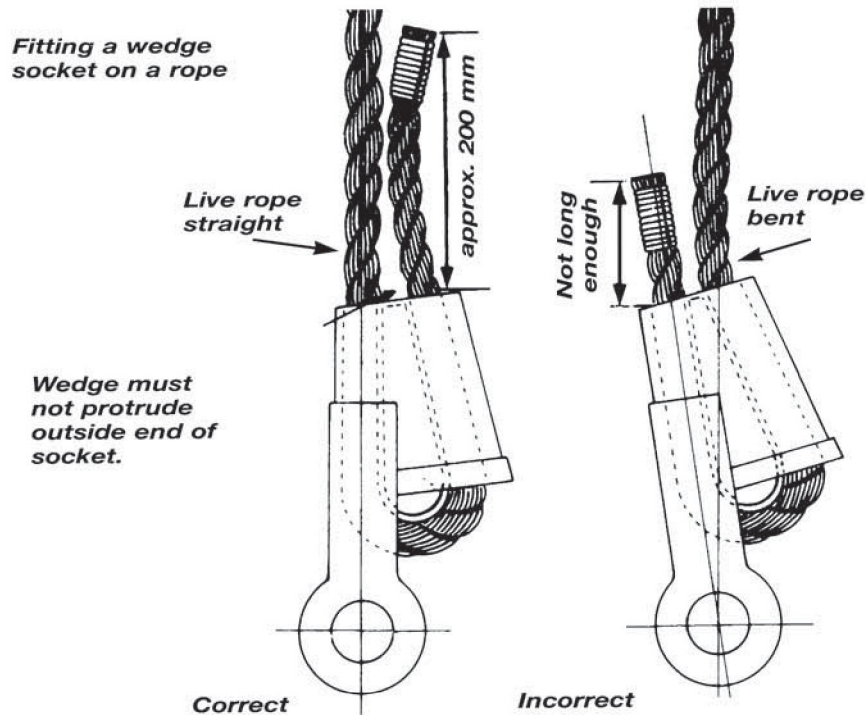

There are many dangers associated with wedge type sockets and riggers should ensure that they are set up correctly.

The rope diameter must be equal to the diameter inside the socket, and when the wedge is pulled tight the wedge must not protrude beyond the socket body.

The hoist rope must be reeved into the socket body so that there is a straight line between the live rope and the anchorage.

If the rope is reeved in the opposite direction so that the live end is on the sloping side of the wedge, the wire will fail at the point where the rope enters the socket.

Do not place rope grips (bulldog clips) across both live rope and the dead end because it can lead to severe damage to the hoist wire. Wedge rope sockets may be used when spliced eyes are difficult to reeve or they would have to be made after the rope is in place.

The wedge rope socket must be properly set up and used, and properly designed and accurately made. They must be designed so that when no rope is fitted the wedge will not pass through the socket.

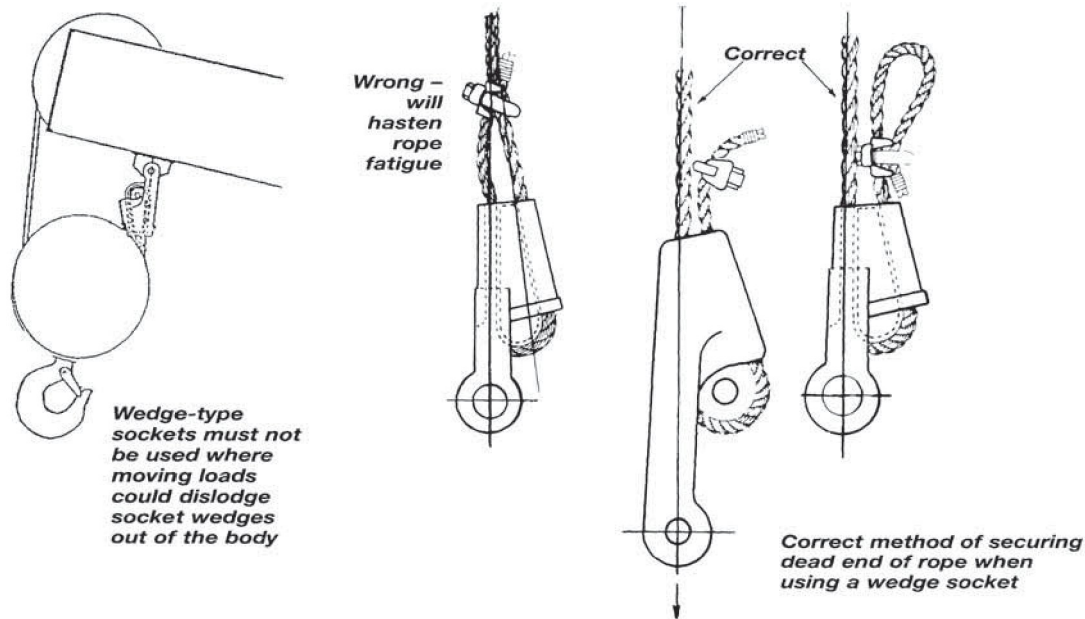

The advantages of using wedge rope sockets as anchorages are simplicity, ease and speed of applying and detaching, and that they do not damage the rope to any appreciable extent.

Sharp edges must be rounded off at the point where the load bearing rope enters or leaves the socket.

The angle of the wedge should be slightly greater than that of the socket, so that it does not tend to nip the rope as it leaves the socket. The angle of the socket is important and should not be greater than 19 degrees.

Do not set up wedge sockets where a block being raised can hit and dislodge the wedge.

Socket bodies and wedges must be frequently inspected for excessive wear at the point the wire rope strands are jammed into them. Do not use wedge rope socket anchorages where they cannot be easily inspected.

The dimensions of the wedge and socket must be such that when a wedge rope socket with rope is assembled, the narrow end of the wedge does not protrude outside the end of the socket. Do not use wedge rope sockets where moving loads can force the wedge out.

A wire rope grip should be applied to the tail (only) of the rope below the socket to prevent dislodgment of the wedge.

In earthmoving equipment such as drag lines and pile drivers the rope is usually initially much longer than required so that shortening can be carried out several times, quickly and easily, without recourse to splicing. The wedge is punched out of the socket, the bad rope cut off and re-reeved through the socket, the wedge replaced and pulled tight. The rope end should always be visible, protruding 150-250mm from the socket so that rope slippage will be evident.

Thimbles

A thimble is a fitting used in the formed eye of a rope and is designed to protect the bearing area inside the crown of the eye from chafing and distortion.

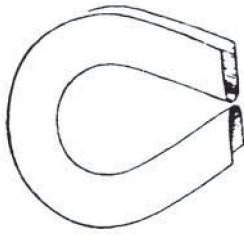

Thimble

Socketed terminal fittings

Metal sockets are suitable for standing ropes. Metal sockets used with running gear will crack the ropes at the entry to the socket as the wires move.

Rapid hoisting, road travelling and impact shocks cause severe vibration in the rope directly above the point of the load attachment. Although a visual examination of the rope at this point may not find broken wires (one broken wire is sufficient to cause it to be condemned), the strength of the section from 1-6 mm above the load attachment is likely to be greatly reduced because of fatigue within the wires.

Sockets (metalled, conical) for steel wire ropes

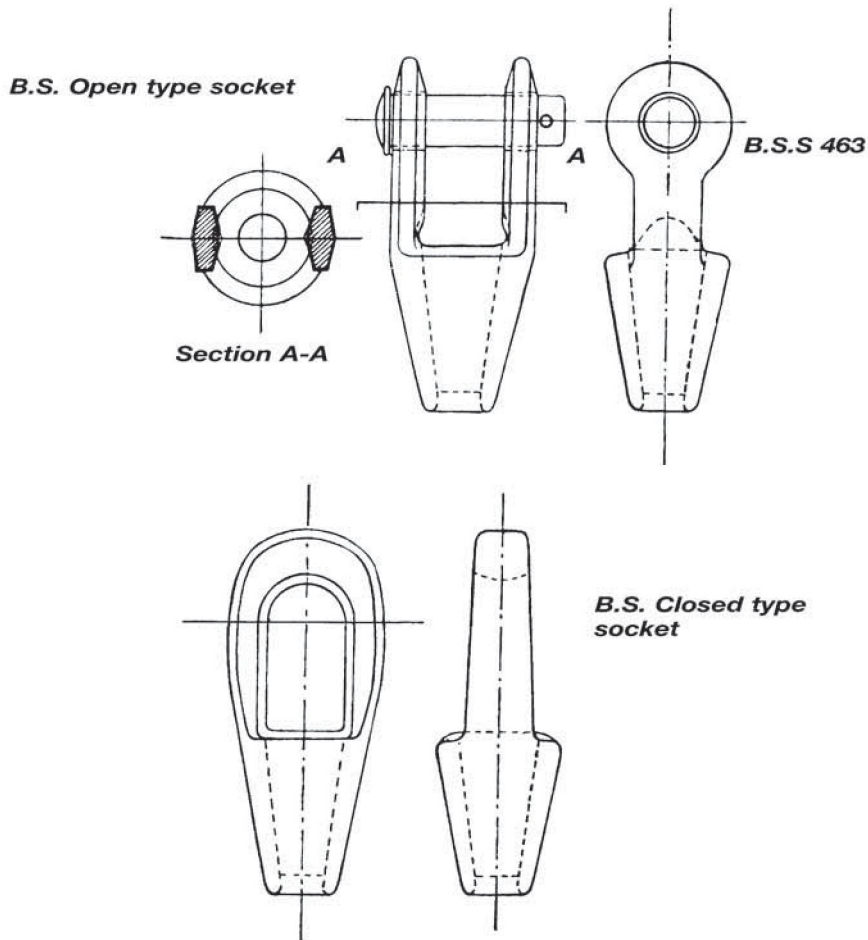

Therefore cut off this damaged section periodically even if it looks sound. About one third of the estimated life of the rope is a good interval.

When socketing or inspecting existing terminals examine closely for corrosion. Corroded wire is very susceptible to fatigue.

After constant vibration, a tensile pull test performed on a sample of the rope which looks sound may disclose a large reduction in its original strength.

A broken rope can kill and can cause severe damage to equipment or plant. Therefore, conduct regular inspections, cropping or renewing wherever vibrational fatigue occurs.

Wire rope grips

Wire rope (or 'bulldog') grips are only suitable for permanent fixed stays or guys.

They can be one of the most dangerous fittings used by riggers if not used correctly. If the bolts are over tightened the rope will be crushed or if the bolts are under tightened slipping will occur.

At least three wire rope grips should be used, with the saddles on the live part of the rope, and the U-bolt pressing on the less heavily loaded tail of the rope. They should be spaced at least six rope diameters apart.

Do not use them on temporary stays or guys that have to be shifted and re-fastened, because of the severe crushing and punishing action of the U-bolt. Do not use sections that are damaged by the clips and then straightened out to take the load.

Installation of wire rope grips (bulldog)

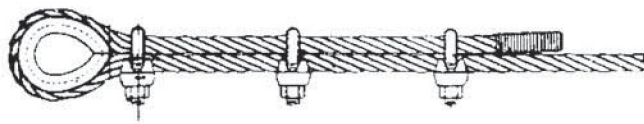

Correct method of fitting wire rope grips

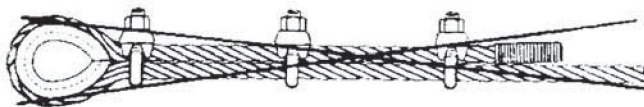

Incorrect method of fitting wire rope grips

Note: Do not fit any or all of the grips with the bridge on the side opposite to the working part of the wire rope.

Do not use bulldog grips on any load hoisting ropes. When connecting a lizard to a stay or guy make sure that the crowns of the U-bolts press upon the lizard. Although they will damage it, they are easily replaced.

Correctly applied, bulldog grips may form an eye with 80 per cent of the breaking strength of the rope. If not correctly applied they may have no reasonable safe value.

Do not use a grip that is the wrong size or that has been strained or damaged.

Do not use a bulldog grip to directly connect two straight lengths of rope. If this is necessary, join two thimbles and then use the grips to make two thimble eyes.

Double or single base clamps (or saddle grips)

Single base clamps are safer than bulldog grips. They have two saddles and two straight bolts. The rope is therefore protected by saddles from severe local damage.

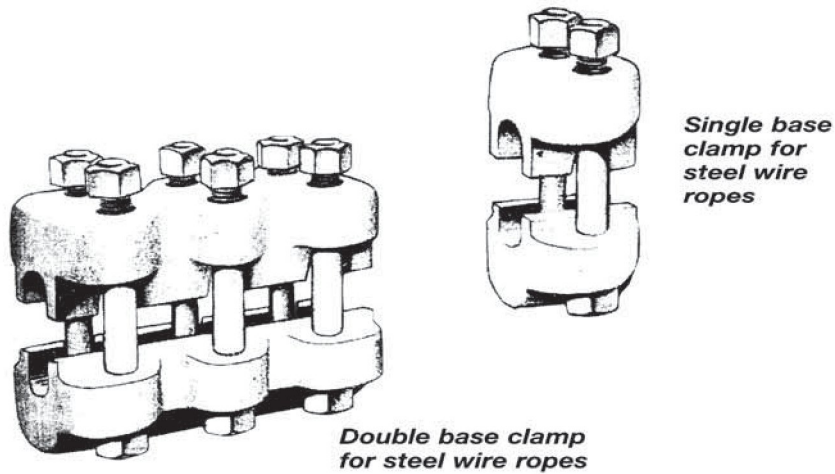

Long double base clamps which are not commonly available extend at least 6 rope diameters in length offering a greater purchase on the rope without causing damage and provide 95 per cent of the strength of the rope. Rope life and safety increase accordingly.

Bordeaux connections

Bordeaux connections are used for connecting wire ropes to chains where the connections must pass over sheaves.

Turnbuckles or rigging screws

Turnbuckle or rigging screws are devices for tensioning or fine length adjustment of FSWR, chain etc. They are also called bottle, union or stretching screws. They should comply with AS 2319 *Rigging screws and turnbuckles*.

Turnbuckles or bottle screws all have a left hand thread at one end and a right hand thread at the other.

They can be shortened or lengthened by twisting the frame or bottle. They can be extremely dangerous where vibration causes them to unscrew. Locknuts should not be put on turnbuckles or bottle screws to prevent unscrewing under vibration.

The thread inside the bottle or frame must be examined for slackness or wear before use. The screw thread is easily seen and is not difficult to examine for defects.

Typical end fittings

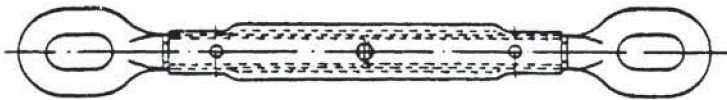

Rigging screw assembly with elongated eyes

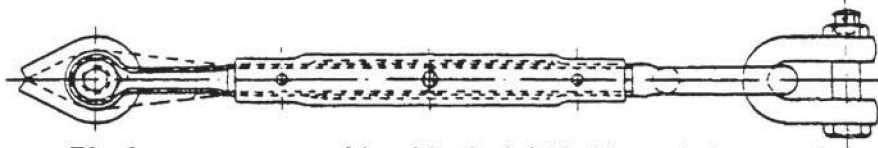

Rigging screw assembly with clevis/thimble and elongated eye/shackle

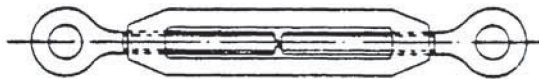

Turnbuckle assembly with round eyes



Turnbuckle assembly with elongated eyes

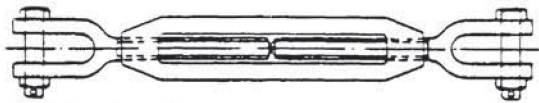

Turnbuckle assembly with clevises

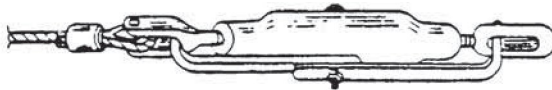

Locking method for turnbuckles and rigging screws

Do not use turnbuckles fitted with a hook to support a load.

Use only eye or clevis type turnbuckles to support a load.

On permanent fixings or anywhere where the rigging screw or turnbuckle may be subject to vibration, the frame should be locked out to prevent slackening.

Rigging screws must have inspection holes which give a view of the amount of thread left in the bottle. Do not use if the thread is absent or if the thread is not fully engaged.

Rigging screws or turnbuckles should never be subject to side pull. The line of pull must be straight.

The WLL must be branded on any turnbuckle or rigging screw that is used for load supporting. Do not use if the brand is absent.

Hooks

There are many different shapes and sizes of hooks. They range from mild steel to very high grade alloy steel. The common factor is that they are all designed to support loads.

Hooks used with chain to make chain assemblies are usually Grade T or Grade 800 strength. Very few, if any, other grades are readily available. Hooks used on chain must not have a WLL marked on them as it will lead to confusion when slings are used. The tag is the only reference to loading of a sling. Chain hooks are marked with their chain size and should be matched to the same size and grade of chain.

Hoist hooks and crane hooks must be marked with the WLL. Some hooks, particularly crane hooks, are also marked with the weight of the hook block.

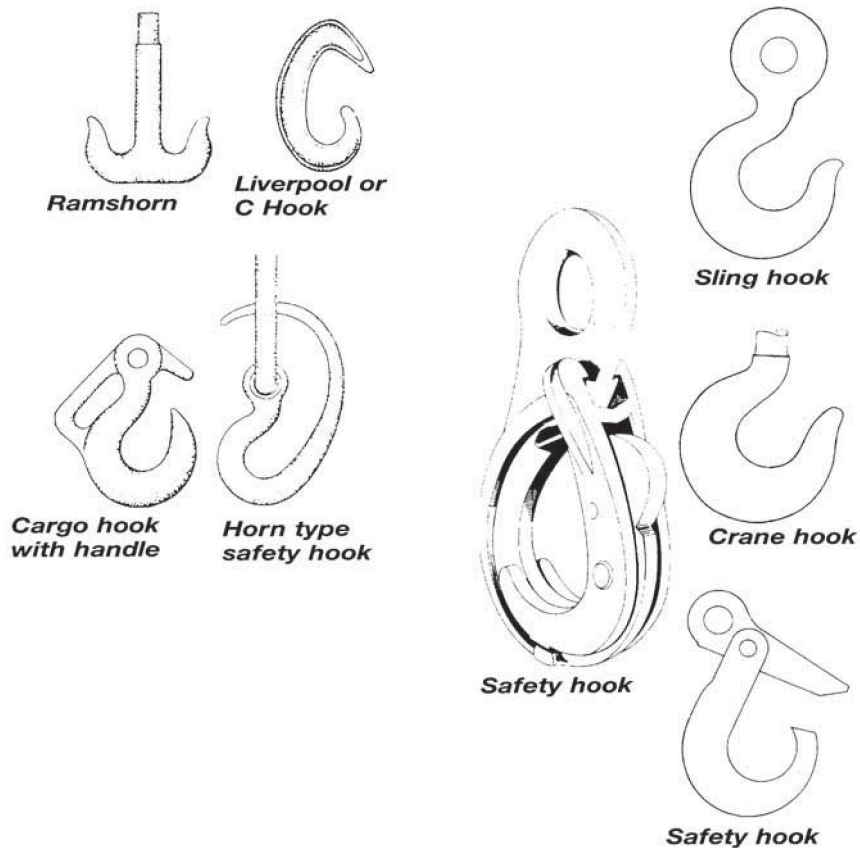

Inspection and use

The opening of the gap between the 'bill' or point of the hook and the shank, must be large enough for any sling, link, ring, shackle, or lifting device to be placed on it. The inside of the bight of the hook should be rounded to avoid cutting any fitting placed on the hook.

Nothing should be placed on a hook which will put opening (stretching) forces on the bill.

Do not use hooks which have had the throat opening stretched more than 5 per cent.

Hooks which are stretched, bent, cracked, or distorted in any way should not be welded or treated by unqualified people. They should be replaced or sent back to the supplier for assessment. Welding can hide a dangerous crack or distortion in the hook.

Hooks should not have any attachments welded to them.

Use a safety hook if there is a chance that the load can become unshipped or displaced. **Caution:** Using some spring loaded safety hooks does not guarantee that slings will not be displaced in some circumstances.

Crane or hoist hooks must be able to freely rotate under all conditions of loading. If the load exceeds 2t, they must have a ball or roller thrust bearing between the trunnion and nut. Make sure that no dust or other foreign matter accumulates in the thrust bearing.

Replace any hook that has the bow worn more than 10 per cent.

Do not place multiple eyes of slings directly on the hook. They should be placed on to a bow shackle, and the pin of the shackle should be placed on the hook.

To avoid excessive forces on the bill of the hook place slings which are at a wide angle on a bow shackle and not directly onto the hook.

It is safer to 'back hook' to the main lifting ring. Taking the chain sling hooks back up to the main hook can be dangerous if the chain slings do not sit properly on the main hook.

Shackles

Shackles are a portable link, used for joining various pieces of lifting equipment. The two main shapes for load lifting are the 'dee' and 'bow' shackles. Almost all shackles are made of round bar and have circular eyes. The pin of the common shackle screws directly into one eye and should preferably have a collar. In some shackles, the pins pass clear through both eyes and are secured by a splitpin forelock (ie split flat cotter pin) or nut and splitpin.

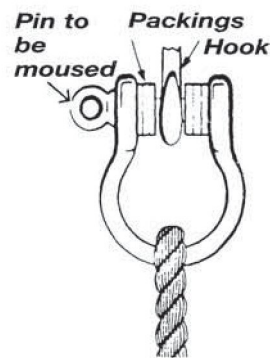
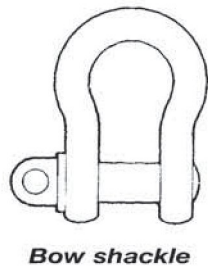
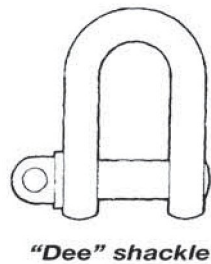

**Good practice –
Pack the pin with
washers to centralise
the shackle**

Shackles are made to AS 2741 *Shackles*. The grades range from grades L and M for small dee and bow shackles to grades S and T for large dee and bow shackles. In order to eliminate projections, shackle pins are sometimes counter sunk flush with the eyes.

The pin and forelock shackle is a safe shackle but is mainly used for standing rigging such as guys.

Always use the correct size shackle pin. Do not use a nut and bolt in place of the proper shackle pin. A bolt that does not fit tightly is likely to bend and break.

Condemn a shackle which is worn either in the crown or on the pin by more than 10 per cent of its original diameter.

Do not use a shackle or pin which is bent, strained, deformed or damaged. Tiny microscopic cracks may have developed during deformation. These can extend under quite small loads and lead to complete failure.

Screw shackle pins should be tightened then loosened very slightly, so that the shackle pin can be unscrewed when the weight is released. If the pins are tightened and the strain is taken on the shackle the pin often jams and is difficult to unscrew.

Where shackles are subject to vibration such as on luffing bridle pendants, mouse the shackle pin to prevent the pin from unscrewing.

Shackles are designed to take vertical forces only. Diagonal forces will strain the shackle and lead to eventual failure.

If any small object such as a single sling or another shackle is placed on the pin the shackle will 'cock bill' or cant. To stop this happening, pack the shackle pin with washers or ferrules to keep the load in the centre of the pin.

When using multiple slings, always use a bow shackle large enough to accommodate all of the eyes safely on the bow. The pin of the shackle should rest on the hook.

Do not use an unmoused screw shackle where the pin can roll under load and unscrew.

Shackles must be branded with the WLL. Do not use a shackle without the WLL clearly marked, for load lifting.

Knocking and leverage can cause vibration which works the pin out of the shackle. To prevent this use the forelock, or the pin with the nut and cotter pin.

Plate shackles are a special shackle made from steel plate with a hole drilled in either end. Two plates are joined by placing bolts through the holes. Plate shackles are used extensively for joining crane luffing bridle pendants. Make sure that the nuts have split pins and that the split pins are spread to ensure safety.

Eyebolts

Eyebolts are used extensively as lifting lugs on set pieces of equipment. The safest eyebolt is a collared eyebolt. Uncollared eyebolts should only be used where the pull on the eyebolt is vertical.

Only collared eyebolts should be used where the pull is inclined from the vertical. The underside of the eyebolt should be machined and the seating upon which the eyebolt is tightened should also be machined. The eyebolt should be tightened so that both faces meet in a neat tight fit. If both faces are apart the collar is of no use.

Any diagonal tension applied to an eyebolt should be in line. The pull should never be across the eye.

Do not insert a hook into an eyebolt. Always use a shackle.

Where two eyebolts are used to lift a load, a pair of slings should be shackled into them. Do not reeve a single sling through two eyebolts and then put both eyes on the hook.

Correct and incorrect methods of slinging uncollared eyebolts

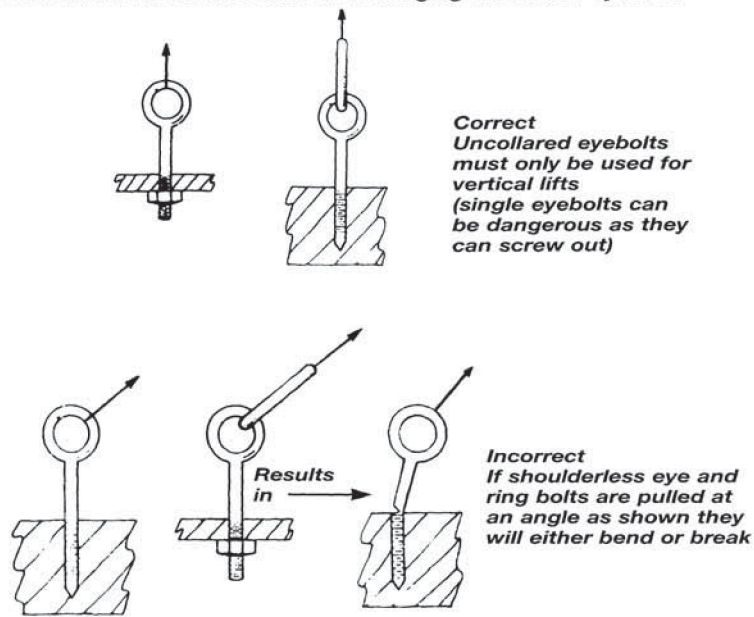

Where eyebolts cannot be kept in line with each other when tightened, insert thin washers or shims under the collars to allow the eyebolts to be tightened when in line.

Do not tighten an eyebolt using a heavy hammer. Use a light hammer or a podger bar. After tightening check the 'solid feeling' which indicates a properly fitted eyebolt.

Loads can spin when lifted with a single eyebolt causing the eyebolt to unscrew from the load. Mouse the eyebolt to the load to stop unscrewing.

Eyebolts are often put on large motors or similar to lift the casing off. It can be dangerous to lift loads with the eyebolts that are provided on the load. If no information is provided about an eyebolt sling the load with slings.

Use of collared eyebolts

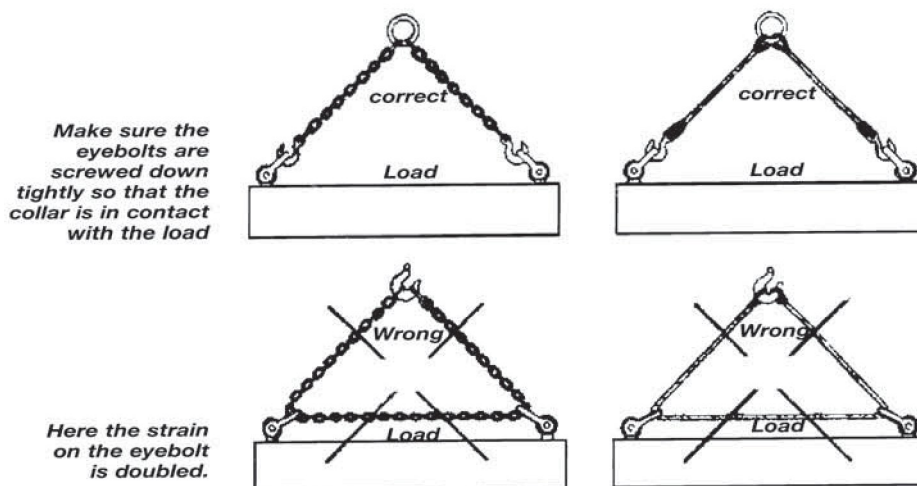

If rings are provided with the eyebolt depend on the WLL of the ring or screw thread, whichever is the weakest.

Where a nut is fitted to the end of screwed thread ensure that it bears evenly on the surface around the hole.

Chapter 7 General rigging appliances

Chain blocks

Chain blocks should comply with AS 1418.2 *Serial hoists and winches*. Some could be dangerous and fail under load. If in doubt check with the supplier.

Chain blocks are used for short lifts such as by small monorail cranes, fixed hoists and so on. They are also frequently used by riggers for transferring or 'fleeting' loads from purchases.



Chain pulley block

Do not drop a chain block. The jolt may distort the casing causing the gearing to malfunction and the chain block to fail. The drive pinion could also part from the main driving spur wheel.

Make sure that the hook has not dipped through itself in a two part or multiple chain fall causing the load chain to twist.

Keep blocks away from sand, grit and dust. Some people keep the load chain lightly oiled to create less friction as the chain passes over the gypsy. If the chain is oiled and it becomes covered in sand or grit, the grit becomes a grinding paste which wears the chain very quickly.

The gypsy in one manufacturer's chain block may not be identical to another. It is important when ordering replacement chain, that the chain and the gypsy are compatible.

Chain blocks with multiple falls are often very heavy on the opposite side to the block. It is a good practice to mouse the block to the head sling, to prevent the hook from dropping out of the head sling when the weight is released from the block.

Maintenance

Inspect the brake lining material for signs of wear and have it replaced if necessary, ensuring the retaining rivets (if any) are well countersunk.

Check the pawl for sharpness and alignment, the pawl spring for effectiveness, and the ratchet teeth for sharpness and wear.

Check the bearing bushes for wear and have them renewed if necessary.

Remove the gear case and inspect the gears for wear on the shafts, and also for bending, breakage, wear, and misalignment of teeth.

Check the load chain for wear and for stretch and the load sheaves for excessive wear. If the load chain does not fit accurately it should be replaced before using the block.

Inspect the load chain guide for movement. This guide should be the fixed type not a small roller. The purpose of the guide is to guide the load chain, free of turns, on to the gypsy. If a roller guide is fitted, hang the block up and while lowering the empty hook, gently twist the ascending chain as it approaches the guide roller. If it jams, a new guide must be fitted.

Check the hooks for opening out due to overloading or misuse. Examine the hook yokes, ball bearing swivels and anchorages of chain to clevis pins.

Where a chain block needs major overhaul or repair, advice should be sought from the supplier about the work to be carried out, and should be done by people who are competent.

Chain blocks must be lubricated lightly. If too much grease is pumped into a chain block the grease could cover the brake and the chain block would fail.

Do not leave a chain block soaking in oil. The oil will saturate the brake.

Pull lifts

There are two types of lever operated chain pullers:

1. those fitted with bush roller chain
2. those fitted with calibrated chain.

A load supported by a bush roller chain pull lift should either be in guides or fixed into a position where side pull cannot be placed on the chain.

Do not extend the handle to give extra leverage. Doing this will overload the pull lift.

Inspection and maintenance is similar to chain blocks.

There are two types of FSWR lever operated pullers:

- the drum type
- the creeper type.

The drum type has a safety ratchet and pawl. The pawl must be held by hand when lowering. Do not tie the pawl back because this can cause control to be lost.

The FSWR used in these winches must be the type recommended by the manufacturer.

The inspection of the FSWR and the anchorages must be done daily to ensure that the winch is safe to hold the load. A complete inspection must be done monthly, with particular attention to the hoist rope.



Calibrated chain puller

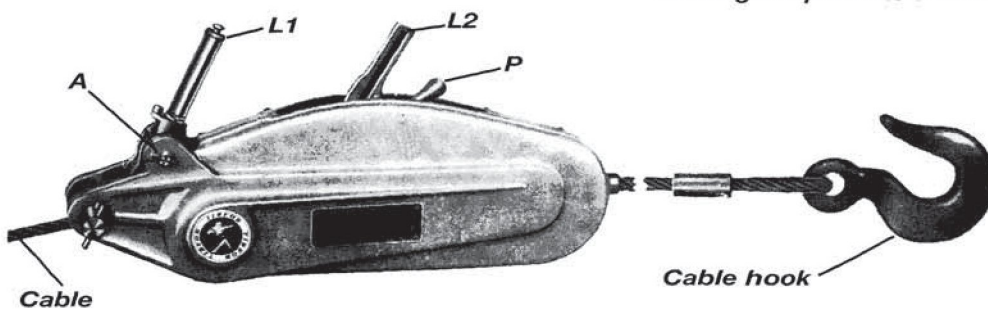

Through rope lever FSWR

Creeper type lever operated pullers have an advantage over drum type pullers because they have unlimited drift.

Without gears, pawls and ratchets, the design enables the rope to pass through the unit in a straight line and is not wound on a drum.

Two pairs of forged steel jaws control the lifting and lowering of the load by a hand lever. The weight of the load actuates the jaws. The wire rope is at all times held by one pair of jaws while the other pair having been opened by cams, is moved by the lever for the next gripping or pulling motion. This method draws a wire rope of any length through the unit.

Caution: The rope can slip through these types of pullers because of the constant diameter in the cam gripping mechanism and because FSWR reduces in diameter under constant loading.

Operation

1. Place the hook on the ground, hold the machine at an angle and push down on the clutch release 'P' towards the anchoring hook until it is seated in the notch.
2. Pull the rope through the machine until the required length is reached.
3. Close clutch 'P'.

Forward or lifting motion. Place the handle on the lever 'L1', then pull and push alternatively.

Reverse or lowering motion. Place the handle on 'L2', and work with the same motion.

Release, pull and push alternatively on 'L2' to slacken the rope, then declutch 'P'.

Spreader beams

Spreader beams are devices which spread the load evenly for a given lift. They are generally made to suit a particular job. Most have a central lifting point for the crane or lifting medium, and have two or more lugs underneath to take the load slings.

All spreader beams must be suitable to lift the particular load and must be branded with the WLL. The WLL must include the weight of the load plus all lifting gear (slings, shackles etc).

Some spreader beams are fitted with offset lugs on the top and are designed to raise loads level even though they are heavy on one end.

For example, there are types of spreader beams used in power stations with sliding lifting lugs used to fit the rotor into the stator. This is done by sliding the lugs along the spreader until the rotor is level.

There are loads such as pre-stressed concrete beams which are designed to take downward forces only. This is opposite to the forces imposed by lifting in the centre.

There are two methods of overcoming this problem:

1. use slings of sufficient length so that the beam can be lifted near the ends and still have a safe angle. For this method to be successful the crane or lifting medium has to have enough drift to place the beam into position
2. use a spreader beam of sufficient length and strength to lift the beam. This method is the best if drift is a problem.

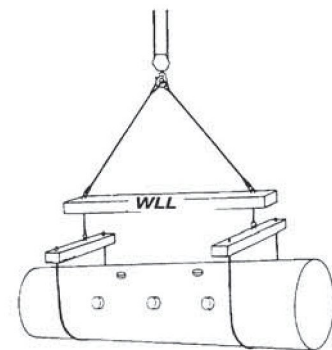

Spreader beam

Equalising gear

Equalising sheaves are load supports, which transfer the load from one single point to two others by means of FSWR. Chain and fibre rope are rarely used. There are several different types of equalising gear, which all do a similar job.

Equalising sheaves transfer the weight on the single point equally to the two points which take half the load each.

If the two points are of unequal capacity, the load on the single point should never exceed double the capacity of the weakest of the two other lifting points.

If one of the two lifting points remains stationary and the other hoists up, the sheave is then a hauling sheave not an equalising sheave. Friction must then be taken into account when working out the weight on the hauling part.

If the capacity of the crane is equal to the load imposed on the crane then the capacity could be exceeded by the additional load due to friction in the sheave system.

Equalising sheaves are often used on bridge or gantry cranes which have a four part purchase with two hauling parts attached to the hoist drum. The opposite or stationary side passes over an equalising sheave.

The function of the equalising sheave is to move as the hoist block swings sideways. The part of FSWR that passes over the sheave has abrasion and fatigue. It takes half of the weight of the hoist block at all times. It also takes half the weight of the load, plus half of the weight of the hoist block when the crane is lifting. It is the hardest working piece of rope on the crane and must not be overlooked by maintenance personnel.

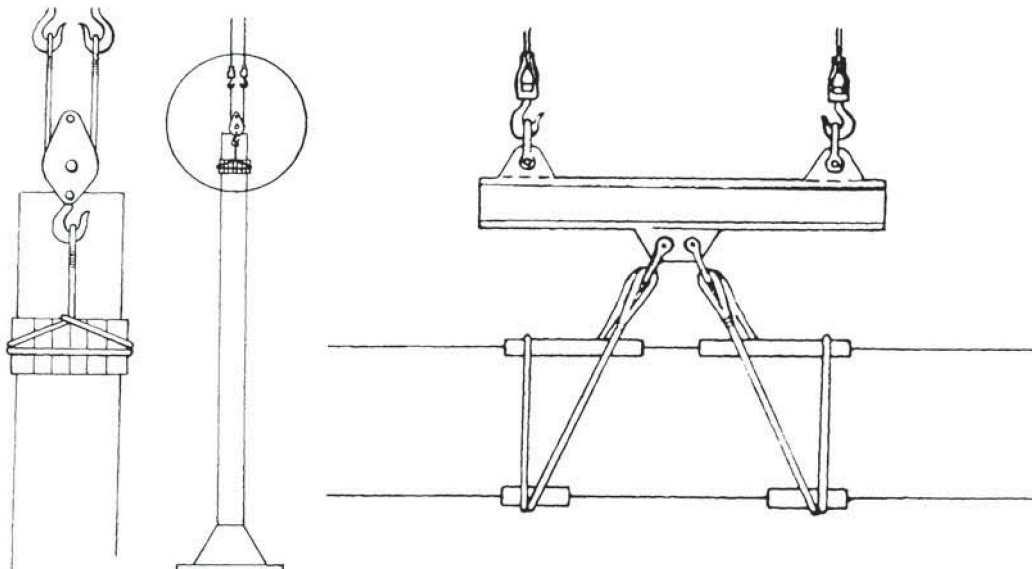

Slinging loads lifted by two cranes. Use of equalising sheave.

Slinging from an equaliser beam with bowsings

Jacks

Jacks are used when it is not suitable to use a crane or hoist to raise or lower a load.

Car jacks have no rated WLL and should not be used as load lifting jacks.

Preparation

Packing under jacks should be independent of other packing. All wedges should be driven home well, and spiked in position if they are left for any time.

To prevent a load that is higher than it is wide from overturning make sure it is supported by side guys or toms. Adjust the guys and toms as the load is lifted.

Do not exceed the WLL branded on jacks. Where possible use a jack that has a larger capacity than is needed to allow for a possible malfunction.

Jacks should be placed on a timber pad and have a timber pad placed on the head to prevent slipping.

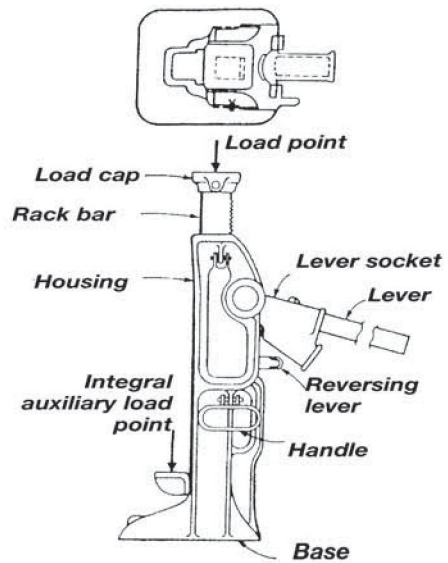
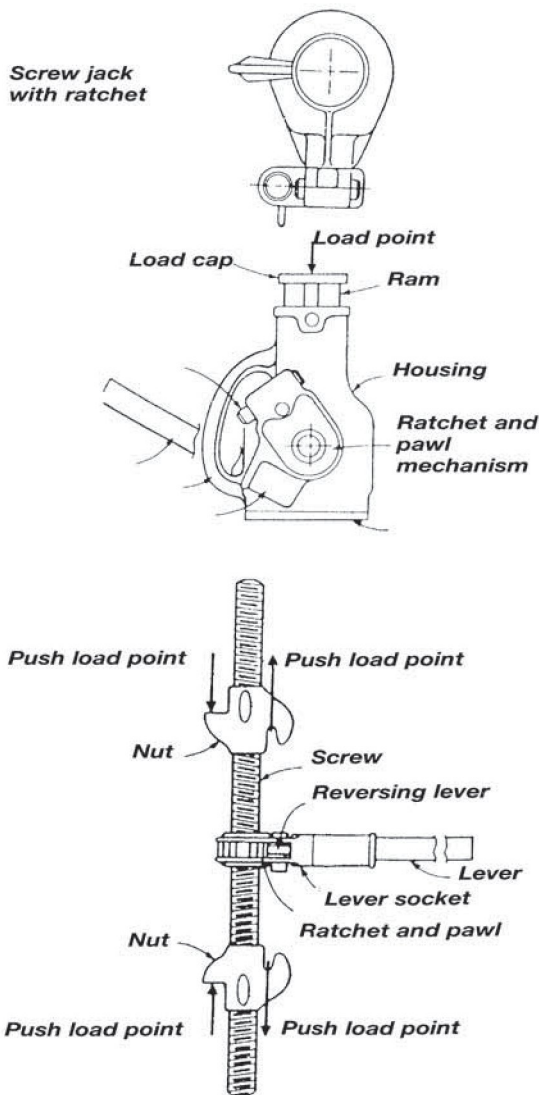

Typical ratchet jack. Track jacks look similar, but are trip-lowering and are not intended for use as general-purpose jacks.

Screw or bottle jacks should be followed up by packing very closely, as the pull in the tommy bar in the screw head can cause the jack to shift.

Examine the condition of the pawl, the teeth of the ratchet, and the handle. Make sure that they are in good condition before lifting.

Test the operation of the quick release before lifting a load.

Lifting

The head of the jack is designed to take the greatest load. Lift on the head when the load can be lifted either on the head or the toe of the jack.

Care should be taken when lifting with geared, or platelayer jacks. Lifting on the head should not be carried out with this type of jack unless special precautions are carried out to ensure stability. When lifting on the head a 600mm to 1m space is needed to place these types of jack in position.

Look out for the head making contact with projections or the jack kicking out when lifting on the toe, especially when lowering.

Make sure the load is kept steady while raising the load. Do not lift both ends of the load simultaneously.

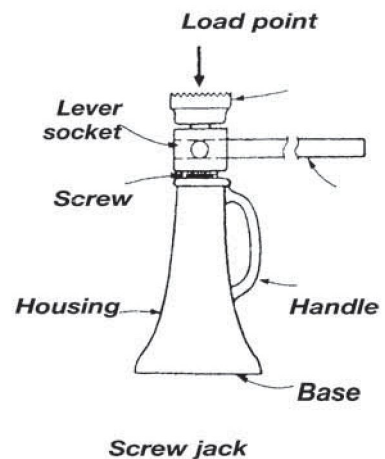

Use the lowest gear when lifting a load near to the maximum capacity of the jack.

The lift must be vertical. If the jack shows signs of tilting, pack the load, release the jack and reset.

Do not extend the jack handle to increase leverage because this will overload the jack.

Take care when releasing the ratchet from the pawl during lowering. Control can easily be lost with the likelihood of injury.

Hydraulic jacks

Use the correct oil and make sure the oil reservoir is full and free from dirt or grit.

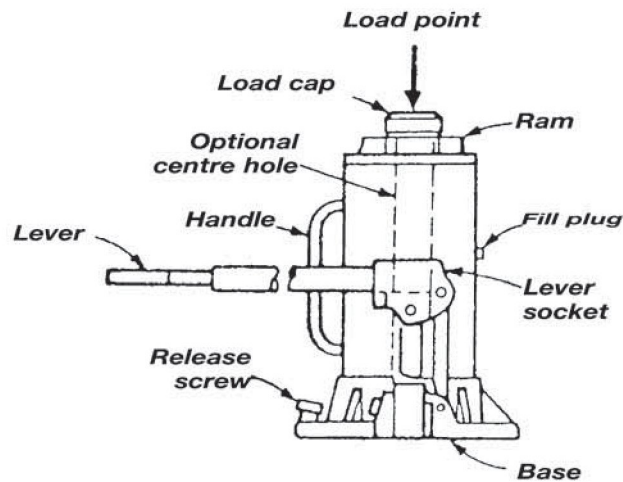

Self-contained hydraulic jack

Make sure the plunger rubbers and ram rubbers are a good fit, softened in neatsfoot or hydraulic oil, and immersed when not in use.

The release valve should operate satisfactorily or be adjusted by a competent person.

All worn rams, pistons, plungers, gears, ratchets, etc should be discarded and replaced.

Fixed cantilevered beams

Cantilevered beams (needles) bolted down to floor beams and held by counterweighting or other means are often used for single whip beams hoists, to support a block and tackle, or a chain block.

A cantilever must be set up so that no more than one third of the length protrudes beyond the outer point of support. An engineer should make the calculations for steel beams. For timber needles see the tables that follow.

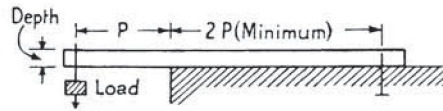

SAFE WORKING LOADS IN TONNES AT ENDS OF CANTILEVERED OREGON NEEDLES											
<i>(To obtain safe working loads for ordinary hardwood multiply values given below by 2)</i>											
Depth	Width	Projection from Support in mm or metres ("P")									
		300 mm	450 mm	600 mm	750 mm	900 mm	1.2 m	1.5 m	1.8 m	2.1m	2.4 m
mm	mm	tonnes	tonnes	tonnes	tonnes	tonnes	tonnes	tonnes	tonnes	tonnes	tonnes
100	75	0.35	0.25	0.18	-	-	-	-	-	-	-
100	100	0.475	0.35	0.25	-	-	-	-	-	-	-
125	75	0.55	0.4	0.275	0.25	-	-	-	-	-	-
125	125	0.925	0.625	0.45	0.4	0.3	-	-	-	-	-
150	75	0.8	0.525	0.4	0.35	-	-	-	-	-	-
150	100	1.1	0.7	0.525	0.425	0.35	0.27	-	-	-	-
150	150	1.6	1.05	0.8	0.65	0.57	0.4	0.3	0.25	-	-
175	100	1.45	0.95	0.725	0.575	0.47	0.35	0.3	-	-	-
175	175	2.55	1.7	1.25	1.0	0.85	0.67	0.5	0.42	0.32	-
200	75	1.4	0.95	0.7	0.575	0.47	0.35	-	-	-	-
200	100	1.9	1.25	0.95	0.75	0.62	0.47	0.37	-	-	-
200	150	2.8	1.9	1.4	1.15	0.95	0.7	0.55	0.47	-	-
200	200	3.8	2.5	1.9	1.5	1.25	0.95	0.75	0.67	0.55	-
225	75	1.8	1.2	0.9	0.72	0.6	0.45	0.35	-	-	-
225	150	3.6	2.4	1.8	1.45	1.2	0.9	0.7	0.6	0.5	0.45
225	225	5.4	3.6	2.7	2.15	1.8	1.35	1.05	0.9	0.77	0.67
250	75	2.25	1.5	1.12	0.9	0.75	0.55	0.45	0.37	-	-
250	150	4.5	3.0	2.25	1.75	1.5	1.12	0.9	0.75	0.62	0.55
250	200	5.9	3.95	2.95	2.4	1.95	1.47	1.2	1.0	0.85	0.75
250	250	7.9	5.0	3.95	3.0	2.5	1.97	1.5	1.25	1.1	1.0
300	100	4.3	2.85	2.15	1.7	1.4	1.07	0.85	0.7	0.6	0.52
300	150	6.45	4.3	3.22	2.55	2.15	1.6	1.27	1.07	0.92	0.8
300	200	8.6	5.75	4.3	3.4	2.8	2.15	1.7	1.4	1.2	1.05

Counterweighting Cantilevered Beam

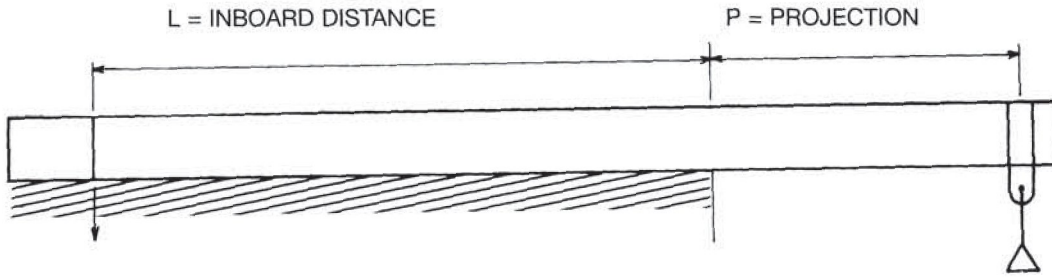

Formula for determining uplift

$$= \frac{\text{Total weight} \times \text{projection}}{\text{Inboard distance}} = \frac{W \times P}{L} = \text{uplift}$$

Formula for determining counterweight

$$= \frac{\text{Total weight} \times \text{projection} \times \text{safety factor}}{\text{Inboard distance}}$$

$$= \frac{W \times P \times SF}{L} = \text{counterweight}$$

Example

Weight to be lifted = 2 tonne

Projection = 1 metre

Inboard distance = 2 metre

Safety Factor = 3

Uplift = $\frac{W \times P}{L}$

L

= $\frac{2 \times 1}{2}$

2

= 1 tonne uplift

counterweight = $\frac{W \times P \times SF}{\text{Inboard}}$

= $\frac{2 \times 1 \times 3}{2}$

= $\frac{6}{2}$

= 3 tonne counterweight

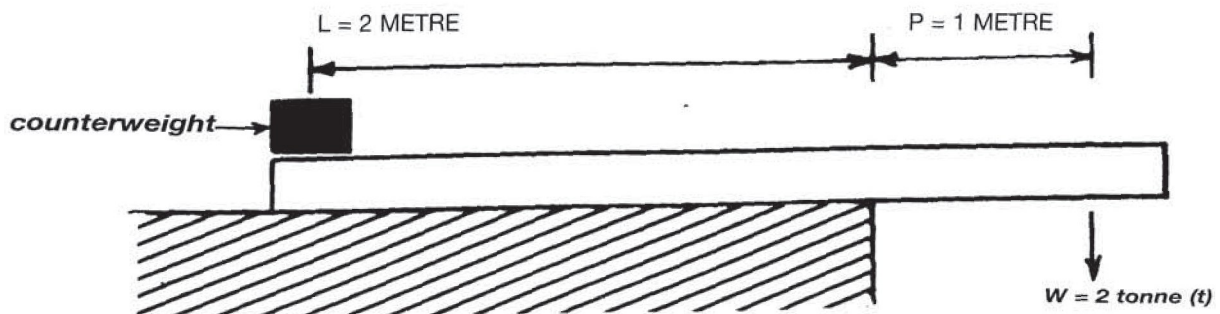

Chapter 8 Slings and working loads

There are many variables in working out the safe method of slinging a load and placing it into position. These include the load weight, size, where the load is to be slung, the sling size, wind, rain and where the load is to be placed.

To ensure a safe lift the rigger or dogman should discuss the placement of the load and the capacity of the crane at that radius with the crane operator. It is then time to sling the load, tie on a tag line where necessary and then guide the crane operator to lift, move and place the load safely.

WLL tables are available for all types of slings and rope. Make sure that you consult the correct table before lifting.





Working load limit

The working load limit (WLL) of a sling is the maximum load that load limit may be lifted by that sling making a straight lift. The load factor for a straight lift = 1.

The WLL can be calculated by dividing the guaranteed breaking strain (GBS) by a safety factor. In general rigging work the safety factor for FSWR is 5.

Below are the rule of thumb methods for calculating the WLL of FSWR, natural fibre rope and chain.

For the exact WLL consult the tags on the FSWR or chain or the relevant WLL tables. If there is no tag on FSWR it must be assumed that it has been made from 1570 MPa steel wires.

Method of Loading	Direct Loaded	Choke Hitch		Basket Hitch									
		 Round load	 Rect. load	 Round load					 Rectangular load				
Included angle a	-	-	-	0°	45°	60°	90°	120°	0°	45°	60°	90°	120°
Loading factor	1.00	0.75	0.50	2.00	1.85	1.73	1.41	1.00	1.00	0.92	0.87	0.71	0.50
Nominal rope dia. mm	Safe working load - tonnes												
	6 X 24 (15/9/F) - 1570 GRADE - GALVANIZED												
8	0.57	0.43	0.28	1.1	1.0	0.99	0.81	0.57	0.57	0.53	0.50	0.40	0.28
9	0.72	0.54	0.36	1.4	1.3	1.2	1.0	0.72	0.72	0.67	0.63	0.57	0.36
10	0.89	0.67	0.45	1.8	1.6	1.5	1.2	0.89	0.89	0.83	0.77	0.63	0.45
11	1.1	0.81	0.54	2.1	2.0	1.8	1.5	1.1	1.1	1.0	0.94	0.76	0.54
12	1.3	0.96	0.64	2.5	2.3	2.2	1.8	1.3	1.3	1.2	1.1	0.91	0.64
13	1.5	1.1	0.75	3.0	2.8	2.6	2.1	1.5	1.5	1.4	1.3	1.0	0.75
14	1.7	1.3	0.88	3.5	3.2	3.0	2.5	1.7	1.7	1.6	1.5	1.2	0.88
16	2.3	1.7	1.1	4.6	4.2	4.0	3.2	2.3	2.3	2.1	2.0	1.6	1.1
18	2.9	2.2	1.4	5.8	5.4	5.0	4.1	2.9	2.9	2.7	2.5	2.0	1.4
20	3.6	2.7	1.8	7.2	6.6	6.2	5.0	3.6	3.6	3.3	3.1	2.5	1.8
22	4.3	3.2	2.1	8.7	8.0	7.5	6.1	4.3	4.3	4.0	3.7	3.0	2.1
24	5.1	3.8	2.5	10.2	9.5	8.9	7.3	5.1	5.1	4.7	4.4	3.6	2.5
26	6.0	4.5	3.0	12.1	11.2	10.5	8.5	6.0	6.0	5.6	5.2	4.2	3.0
28	7.0	5.2	3.5	14.0	13.0	12.1	9.9	7.0	7.0	6.5	6.1	4.9	3.5
32	9.1	6.8	4.5	18.3	16.9	15.8	13.0	9.1	9.1	8.4	7.9	6.4	4.5

A safe working load chart for 6 x 24 - 1570 Grade - Galvanised Steel Wire Rope

Working load limit of flexible steel wire rope (FSWR)

To calculate the WLL in kilograms of FSWR, square the rope diameter (D) in millimetres (mm) and multiply by 8.

Formula: WLL (kgs) = D² (mm) x 8

For example: Rope diameter (D) = 12mm

$$\begin{aligned} \text{WLL (kgs)} &= D^2 \text{ (mm)} \times 8 \\ &= D \text{ (mm)} \times D \text{ (mm)} \times 8 \\ &= 12 \times 12 \times 8 = 1152\text{kgs} \quad \text{WLL (t)} = 1.15 \end{aligned}$$

tonnes

The above equation can be reversed to calculate the diameter (D) in millimetres of FSWR needed to lift a given load. To do this divide the load (L) in kilograms by 8 and find the square root of the result.

Formula: D (mm) = $\sqrt{\frac{L(kg)}{8}}$

For example: Load = 1152kg

$$D \text{ (mm)} = \sqrt{1152 \div 8}$$

$$= 144$$

$$= 12 \text{ (mm)}$$

Therefore an FSWR sling of at least 12mm is required to lift a 1152kg load for a straight lift.

Working load limit of chain

The WLL of chain is determined by the grade (G).

Do not use a chain to lift if it does not have a manufacturer's tag that gives details of the WLL. Return it to the manufacturer for WLL assessment and retagging.

To calculate the WLL of 80 grade lifting chain in kilograms square the diameter (D) in millimetres (mm) and multiply by 32.

Formula: WLL (kgs) = D² x 32

For example: Chain diameter, 10mm. Grade T (80)

$$\begin{aligned} \text{WLL} &= D^2 \text{ (mm)} \times 32 \\ &= D \text{ (mm)} \times D \text{ (mm)} \times 32 \\ &= 10 \times 10 \times 32 \\ &= 3200\text{kg s} \\ \text{WLL (t)} &= 3.2 \text{ tonnes.} \end{aligned}$$

The above equation can be reversed to calculate the diameter (D) in millimetres of chain needed to lift a given load. To do this divide the load (L) in kilograms by 32 and find the square root of the result.

Formula: D (mm) = $\sqrt{L \text{ (kgs)} \div 32}$

$$\begin{aligned} \text{Load} &= 3200\text{kg} \\ D \text{ (mm)} &= \sqrt{3200 \div 32} \\ &= \sqrt{100} \\ &= 10 \text{ (mm)} \end{aligned}$$

Therefore a Grade 80 chain, 10mm in diameter is required to lift a load 3200kg for a straight lift.

Warning: The above formulas must not be used for any other load lifting chain which is less than Grade 80 (t).

To calculate the WLL of grade 30 or 40 lifting chain in kilograms, square the diameter (D) in millimetres (mm) and multiply the grade (G) by 0.3.

Formula: WLL (kgs) = D²(mm) x G x 0.3

For example: Chain diameter, 10mm. Chain grade 30

$$\begin{aligned} \text{WLL} &= D^2 \text{ (mm)} \times G \times 0.3 \\ &= D \text{ (mm)} \times D \text{ (mm)} \times G \times 0.3 \\ &= 10 \times 10 \times 30 \times 0.3 \\ \text{WLL} &= 900\text{kgs} \\ \text{WLL (t)} &= 0.9 \text{ tonnes} \end{aligned}$$

Working load limit of natural fibre rope

To calculate the WLL of natural fibre rope in kilograms square the rope diameter (D) in millimetres (mm).

Formula: WLL (kgs) = D²(mm)

For example:

$$\begin{aligned} \text{Diameter} &= 25\text{mm} \\ \text{WLL (kgs)} &= D^2(\text{mm}) \\ \text{WLL (kgs)} &= D (\text{mm}) \times D (\text{mm}) \\ &= 25 \times 25 \\ &= 625\text{kgs} \\ \text{WLL (t)} &= 0.625 \text{ tonnes} \end{aligned}$$

The above equation can be reversed to calculate the diameter (D) in millimetres of fibre rope needed to lift a given load. To do this find the square root of the load in kilograms.

$$\text{Formula: } D (\text{mm}) = \sqrt{\text{Load (kgs)}}$$

$$\begin{aligned} \text{Load} &= 200\text{kgs} \\ \sqrt{D (\text{mm})} &= 200 \\ &= 14.14 (\text{mm}) \end{aligned}$$

Therefore a 15mm diameter fibre rope sling is required to lift a 200kg load for a straight lift.

Working load limit of flat webbing and round synthetic slings



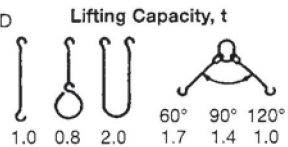



Flat webbing and round synthetic slings are labelled with the WLL. **Do not** lift if the label is missing. Return the sling to the manufacturer for assessment and relabelling. Synthetic slings are colour coded. (See table below.)

WLL 1.0t							
MATERIAL							
DATE							
TEST No.							
MANUFACTURER							
<ul style="list-style-type: none"> CONSULT SLING LOAD CHART FOR CONFIGURATIONS NOT SHOWN DO NOT USE SLING IF THIS TAG IS REMOVED INSPECT SLING FOR DAMAGE BEFORE EACH USE DO NOT USE SLING IF THERE IS ANY SIGN OF CUT WEBBING, SNAGGING, HEAT OR CHEMICAL DAMAGE, EXCESSIVE WEAR, DAMAGED SEAMS, ANY OTHER DEFECTS, OR PRESENCE OF GRIT, ABRASIVE MATERIALS OR OTHER DELETERIOUS MATTER DO NOT TIE KNOTS IN SLING WEBBING PROTECT SLING WEBBING FROM SHARP EDGES OF LOAD DO NOT EXPOSE SLING TO TEMPERATURES ABOVE 90 DO NOT ALLOW ABRASIVE OR OTHER DAMAGING GRIT TO PENETRATE THE FIBRES CONSULT WITH MANUFACTURER'S RECOMMENDATIONS, BEFORE IMMERSING A SLING IN A CHEMICAL SOLUTION KEEP AWAY FROM ... 	<p style="text-align: center;">Lifting Capacity, t</p>  <table border="1" style="margin-left: auto; margin-right: auto;"> <tr> <td>60°</td> <td>90°</td> <td>120°</td> </tr> <tr> <td>1.7</td> <td>1.4</td> <td>1.0</td> </tr> </table>	60°	90°	120°	1.7	1.4	1.0
60°	90°	120°					
1.7	1.4	1.0					

Label for a flat webbing synthetic sling

Synthetic slings are colour coded according to lifting capacity

Label for a flat webbing synthetic sling

Colour No Stripes	Tonne							
		Vertical	Choke	Basket	30°	60°	90°	120°
Violet 1	1	1	0.8	2	1.9	1.7	1.4	1.00
Green 2	2	2	1.6	4	3.8	3.4	2.8	2.00
Yellow 3	3	3	2.4	6	5.7	5.1	4.2	3.00
Orange 4	4	4	3.2	8	7.6	6.8	5.6	4.00
Red 5	5	5	4.0	10	9.5	8.5	7.0	5.00
Brown 6	6	6	4.8	12	11.4	10.2	8.4	6.00
Blue 8	8	8	6.4	16	15.2	13.6	11.2	8.00
Olive 10	10	10	8.0	20	19.0	17.0	14.0	10.00
Grey 12	12	12	9.6	24	22.8	20.4	16.8	12.00

Indicator stripes – each stripe represents 1 tonne WLL – safety factor 8:1

Load factors and slinging

The lifting capacity of a sling for a straight lift is the WLL. Once the WLL has been altered due to a particular slinging method such as an increase in the angle between two legs or a reeve it is then referred to as the safe working load (SWL).

The lifting capacity decreases as the angle between the legs of the sling attachment increases. Different methods of slinging will also alter the lifting capacity.

For example, a reeved sling around a square load will halve the lifting capacity of a sling. This gives a load factor of 0.5.

Riggers must know the load factors for each method of slinging shown below.

Single sling

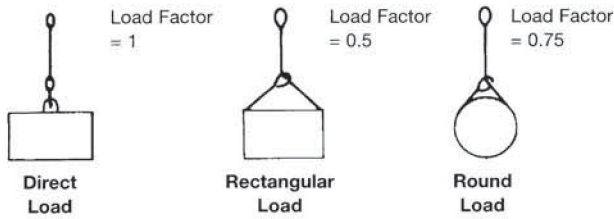

Basket hitch

Single Sling Vertical Legs

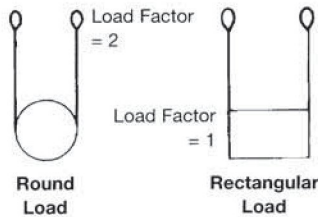

Include Angle Between Legs

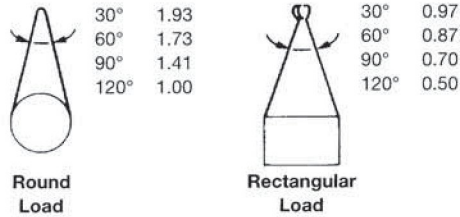

Endless sling or grommet

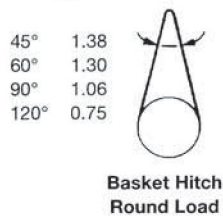

Multiple slings

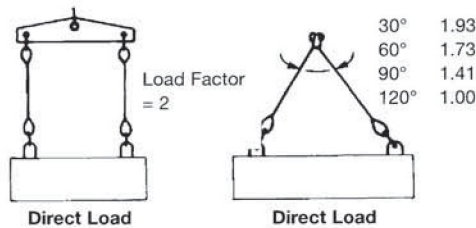

A simple rule of thumb for a good safe working angle is to make sure that the horizontal distance between the points of attachment of the load does not exceed the length of the slings.

This will ensure that the angle between the two legs of the sling does not exceed 60°. At 60° the slings will lift only 1.73 the WLL of one sling.

The recommended maximum angle between the two legs of a sling is 90°. The recommended maximum angle between the vertical and any leg of a sling is 45°. At 90° the slings will lift 1.41 times the WLL of one sling.

When slinging a rigid object with a multi-legged sling it must be assumed that only two of the sling legs are taking the load. Additional legs do not increase the SWL of the sling assembly. Therefore each leg has to be capable of taking half of the weight of the load.





The SWL of a multi-legged sling assembly is assessed on the diagonally opposite legs, which have the largest included angle.

The SWL of slings decreases as the angle between the slings increases or if the slings are nipped or reeved. All factors must be considered when determining which sling is the correct one to lift a given load.



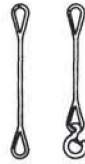

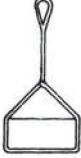
Remember that the rule of thumb method of working out the SWL of slings is not completely accurate. For an accurate SWL refer to the manufacturer's load charts.

Common sling arrangements





Single-part, single-leg slings

Direct Load	Choke Hitch		Basket Hitch	
				
	Round load	Rect, load	Round load	Rectangular load

Double-part, single-leg slings

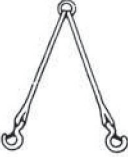
Direct Load	Choke Hitch		Basket Hitch	
				
	Round load	Rect, load	Round load	Rectangular load

Two-leg slings

Direct Load	Choke Hitch			
	Round load		Rectangular load	
				
	Single wrap	Double wrap	Single wrap	Double wrap

Three-leg and four-leg slings

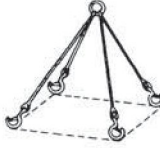
3-leg assembly	4-leg assembly
	

Sample calculations

In the examples below all the load and reeve factors are for FSWR. The arithmetic is set out so that calculations can be easily worked out on a calculator.

- To calculate the maximum weight of load that can be lifted multiply the WLL of the sling(s) by the angle factor by the reeve factor.

Formula: Max load = WLL (of sling) x angle factor x reeve factor.

For example: The WLL of each leg of a two legged sling is 8 tonnes, the angle between the two sling legs is 60° and they are reeved around a square load. This means a load factor of 1.73 for the angle and another factor of 0.5 for the reeve.

Sling WLL 8 tonne
 Angle factor 1.73
 Reeve factor 0.5

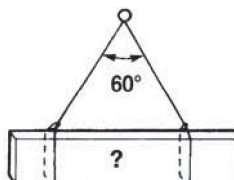

Therefore:

$$\begin{aligned} \text{Max load} &= 8 \times 1.73 \times 0.5 \\ &= 6.92 \text{ tonnes} \\ 6.9 \text{ tonnes} &\text{ is the maximum weight that can be lifted} \end{aligned}$$

2. To calculate the WLL of multi-legged slings needed to lift a load divide the weight of the load by the load factor.

Formula for a calculator: $WLL = \text{weight} \div \text{load factor}$

Formula can be written: $WLL = \frac{\text{weight}}{\text{load factor}}$

For example: The weight of the load to be lifted is 20 tonnes and the angle between the legs of a two legged sling is 60° . This means that the load factor is 1.73 for the angle.

Weight 20 tonnes
Load factor 1.73

Therefore:

$$\begin{aligned} WLL &= 20 \div 1.73 \\ &= 11.56 \text{ tonnes} \end{aligned}$$

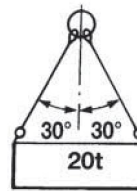

Therefore, use a sling with a lifting capacity greater than 11.56 tonnes.

3. To calculate the WLL of a sling needed to lift a load divide the load by the angle factor and divide by the reeve factor.

Formula for a calculator:

$WLL = \text{weight} \div \text{angle factor} \div \text{reeve factor}$ Formula can be written:

$$WLL = \frac{\text{weight}}{\text{angle factor} \times \text{reeve factor}}$$

For example: Two slings have a 60° angle between them and are both reeved around a 4 tonne square load. This means a load factor of 1.73 for the angle and 0.5 for the reeve.

Weight 4 tonnes
Angle factor 1.73
Reeve factor 0.5

Therefore:

$$WLL = 4 \div 1.73 \div 0.5 = 4.62 \text{ tonnes}$$

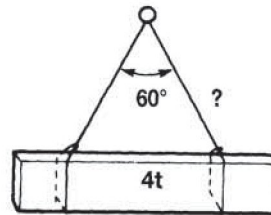

Therefore, use a pair of slings each with a lifting capacity greater than 4.62 tonnes.

4. To calculate the WLL of the sling needed to lift a load divide the load by the angle factor and divide by the reeve factor.

Formula for a calculator:

$WLL = \text{weight} \div \text{angle factor} \div \text{reeve factor}$ Formula can be written:

$$WLL = \frac{\text{weight}}{\text{angle factor} \times \text{reeve factor}}$$

For example: Two slings have a 60° angle between them and are reeved around a 20 tonne round load. This means a load factor of 1.73 for the angle and 0.75 for the reeve.

Weight 20 tonnes
 Angle factor 1.73 Reeve factor 0.75
 WLL = $20 \div 1.73 \div 0.75$
 = 1541 tonnes

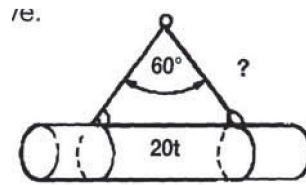

Therefore, use a sling with a lifting capacity greater than 15.41 tonnes.

5. To calculate the diameter (D) in millimetres (mm) of FSWR needed to lift a load (L) of 5 tonnes as a straight lift, convert tonnes into kilograms, divide by 8 and then find the square root of the answer.

Formula: D (mm) = $\sqrt{\text{load} \div 8}$

Formula can be written: **D (mm) = $\sqrt{\frac{\text{Load}}{8}}$**

$$D (\text{mm}) = \sqrt{(5 \times 1000) \div 8}$$

$$D (\text{mm}) = \sqrt{5000 \div 8}$$

$$= \sqrt{625}$$

$$= 25$$

Therefore, a 25mm diameter FSWR is needed for the lift.

Weight of the load

Do not lift if the weight of a load is not stamped on the load or the delivery docket or it is not possible to calculate the weight.

It may be possible to calculate the weight of a load from the weighbridge certificate from the delivery vehicle.

Be careful of the load weight stamped on the load or delivery docket.

Timber for example, can be 50 per cent heavier when wet. In foundries when large castings are raised from a mould there can be suction created by the sand adding substantially to the weight. Pipes are often weighed down by sludge.

Fuel and water tanks may not always be empty. Check for this. When lifting a load for the first time watch the lifting equipment carefully for signs of strain in case the stated weight is incorrect. The operator can confirm the weight of a load using a crane load indicator, if one is fitted.

See 'Areas and Volumes' page 215, for the formulas for calculating the volume of varying shaped objects and the 'Tables of Masses' on page 219.

Direct lifting

Direct the crane operator to position the head of the boom, jib or the bridge directly over the load. The load hook must be positioned directly above a load before slinging and lifting.

Always lift vertically. If the boom, jib or bridge is not directly over the load, the load will begin to swing dangerously as soon as it is raised.

Dragging a load can put undue strain on the lifting gear and crane boom especially if the load is dragged from the side.

General slinging

Make sure that there is suitable packing or lagging at all sharp edges of steel beams, and other hard materials.

Use packing to prevent the sling from coming into contact with sharp edges. This will lengthen the life of the sling and prevent damage to the slings.

Make sure that packing or lagging is secure so that it will not fall out when the slings go slack. Before lifting a load make sure that it is not caught or trapped in some way.

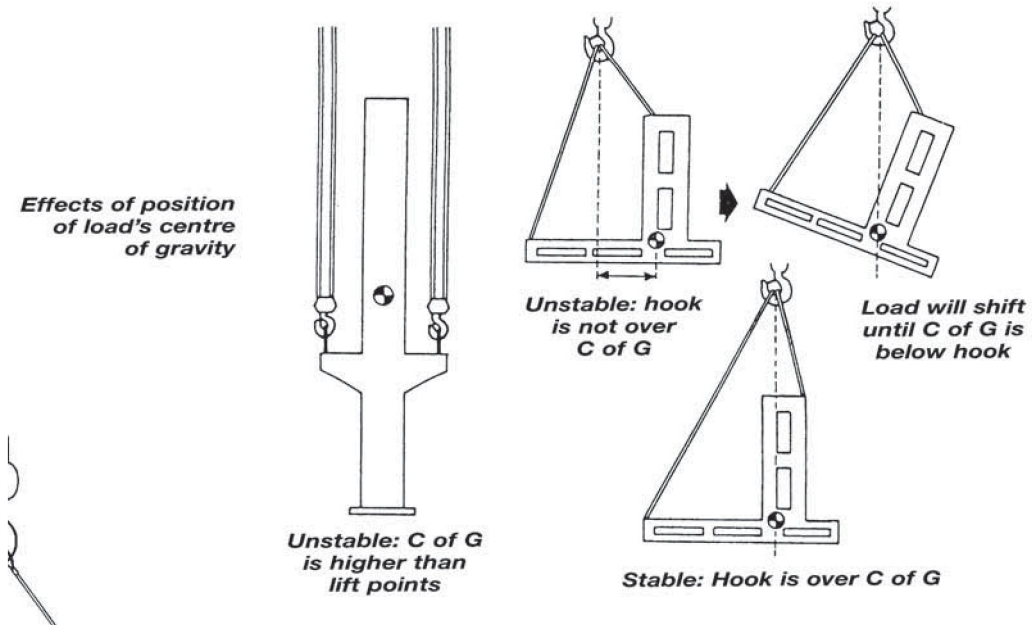

Machinery, plant, personnel or material work boxes and fuel containers with lifting lugs must have the WLL clearly marked.

All loose loads delivered to a site that could be hazardous should be strapped or wrapped.

For example:

- Loads of pipe, metal, timber, purlins and wall girts should be strapped before lifting.

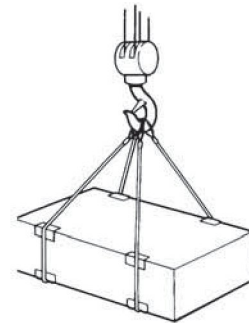

Spreaders are recommended for lifting lengths of timber, pipe or steel. If a spreader is not available – double wrap before lifting.

Use packing to prevent the sling from coming into contact with sharp edges

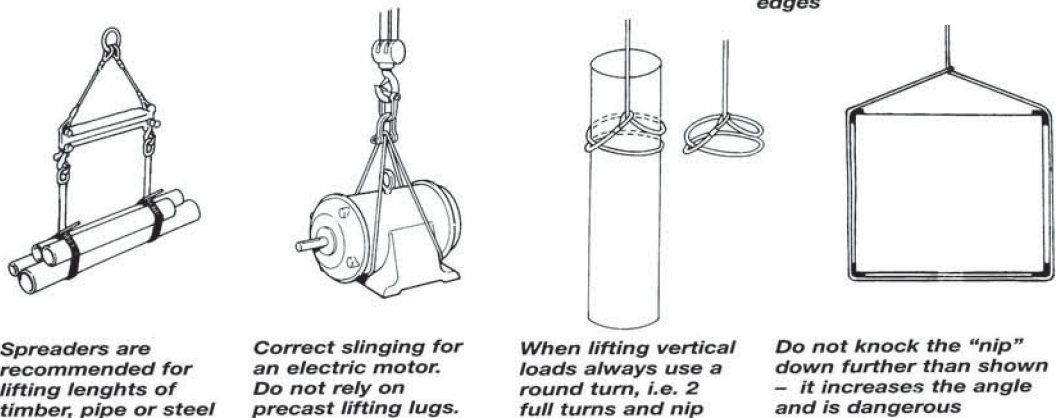

Do not bash the eye of a sling down at the nip point. This practice will decrease the SWL and damage the sling.

Structural steel

Loads of structural steel (universal beams, RSJs) on trucks must have restraining spikes fitted in the truck to prevent them from falling out. Removing the chains or straps if there are no restraining spikes in place is very dangerous. Structural steel can be very dangerous. When a load arrives on site walk around the truck and check that the steel has not shifted into a dangerous position for lifting after the load binder chains were secured.

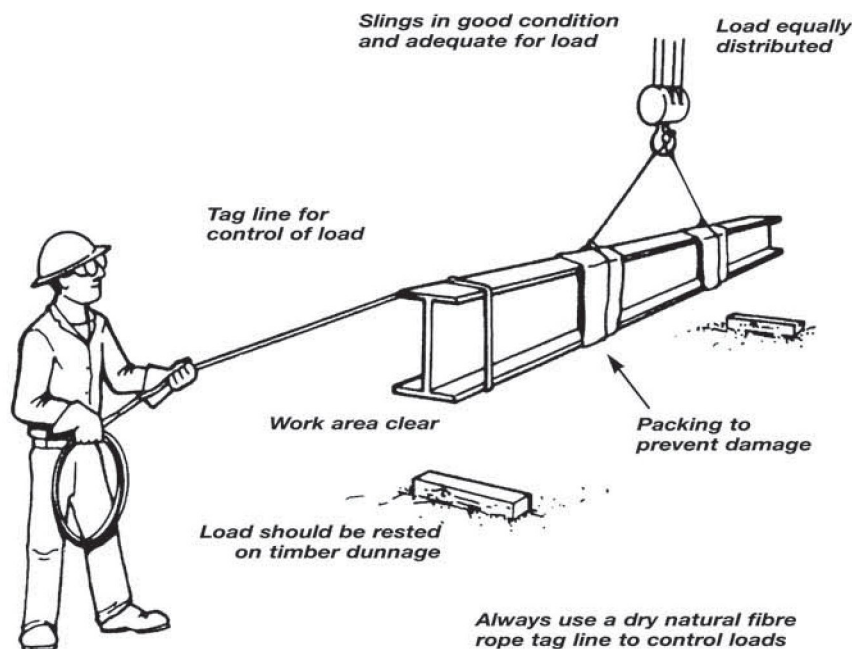

Many serious accidents have occurred as load binding chains were removed from steel beams. Deep beams that are narrower in width than height are unstable and can inflict especially severe injuries.

Always lift bundles of steel reinforcing, beams, pipes and purlins level. Do not lift it vertically or at a slope. It is not possible to make the inside section in a bundle tight enough to prevent them falling out if the bundle is at an angle. Steel reinforcing can kill if it falls.

As the load is lifted keep hands well away. Steel beams tend to snap together or roll up as the sling bites into the nip.

Loose items

Loads of loose items such as scaffold clips must be raised in properly constructed boxes branded with the SWL.

Do not lift loads of this kind in 200 litre drums unless they are in a properly constructed lifting frame with a solid metal base, because:

- these drums have no rated lifting capacity
- it may not be possible to know the condition of the base of the drum (they have usually been discarded because they are unfit to hold liquid)
- the holes cut into the sides for the sling or hooks can pull through under the weight
- the sharp edges of the holes can cut through a sling.

Rubbish bins

Rubbish bins should have proper lifting lugs and be branded with the WLL. Rubbish bins that are overloaded must not be lifted. Where rubbish can be blown out or spill from a bin, secure the load before lifting (especially in windy conditions).

Sling rubbish bins with a four legged sling. To tip the bin, release the two front slings and raise the bin with the two back slings.

Do not stand behind a bin when tipping rubbish out. It will whip back suddenly as soon as it is clear of the ground.

Handling steel plate

Steel plate can be lifted with:

- plate clamps that are designed to increase the purchase on the plate as the plate is lifted
- hooks or shackles where there are lifting holes in the plate.

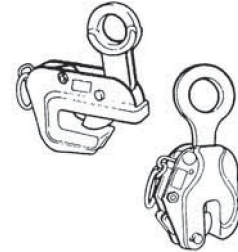

Typical plate clamps

Do not use home made type plate clamps or plate dogs.

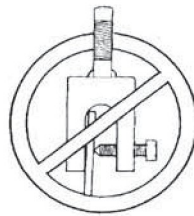

Do not use home made type plate clamps or plate dogs. Remember that steel plate can injure or kill.

Use a spreader beam if the angle between the two legs is likely to be more than 60°

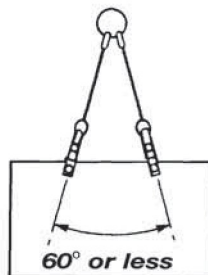

Always use a spreader beam for lifting steel plate if the angle between two slings exceeds 60°

Steel plate can be lifted vertically or horizontally.

Lifting vertically:

- use a plate clamp where a sling cannot be attached and there is no lifting hole. An example is the dished and flanged end plate for a pressure vessel
- **Note:** It can be difficult to remove or attach a sling where plate is stored vertically in a rack or is to be fed into bending rolls
- as a plate touches the ground and the tension is released from the slings a single hook can come out of the hole causing the plate to fall. To prevent this lift with a hook put through a ring attached to short length of chain that is shackled to a plate clamp
- always make sure that the tension remains in the slings until the plate is in place.



Correct set-up for lifting steel plate vertically

Lifting horizontally:

- it is recommended that a minimum of four plate clamps and a spreader beam are used for lifting steel plate horizontally. For horizontal lifts use appropriate plate clamps. Use a spreader beam for long thin plates to prevent dangerous flapping, sagging and vibration.

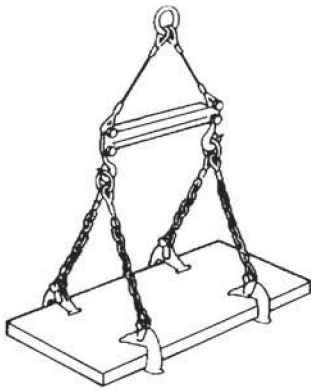

Make sure that the angle between slings when lifting steel plate is 60° or less

Pallets

A wide variety of loads are delivered on pallets. Before a palletted load is lifted from a truck check that:

- the pallet is free from defects
- the load is secured so that nothing can fall off
- the load is properly slung.

The WLL of a standard hardwood pallet is 2000kg. The WLL can be dramatically reduced if there are any missing boards or any other defects. **Note:** Some pallets are designed for packaging not lifting.

Do not lift a pallet that has defects. To lift a load on a damaged pallet raise the load just enough to slide an undamaged pallet underneath. Then lower the load and sling properly before lifting and moving the load to the desired place.

If no spare undamaged pallets are available send the load back to the supplier to be re-palletted.

Always raise palletted bricks inside a brick cage to prevent loose bricks falling.

Loading formwork

When placing concrete out of a kibble onto formwork spread the flow out. Dumping the whole load in one spot can overload the formwork especially if it is also taking the weight of workers and vibrating equipment. Formwork is only designed to take concrete spread out evenly over the whole area.

Make sure that the concrete is poured gradually. The sudden release from a kibble attached to a mobile or tower crane can cause a 'whip back' and the kibble will bounce dangerously.

Turning over loads

When turning over a load such as a steel beam the sling must be attached to the hook on the side of the load that is to be lifted. This will ensure that it will be raised on a diagonal through the centre of gravity.

It is then a simple matter to lower the hook, turning the beam over in a safe and controlled manner.

It is important that the beam is slung so that when the beam is lowered the nip will pull against the eye.

Structural steel members such as universal beams and RSJs have a high centre of gravity and a narrow base when standing on their flange. If a sling is nipped incorrectly the beam will flop, topple over and possibly break the slings.

The same principles apply when turning over all loads.

Correct method of turning over a load

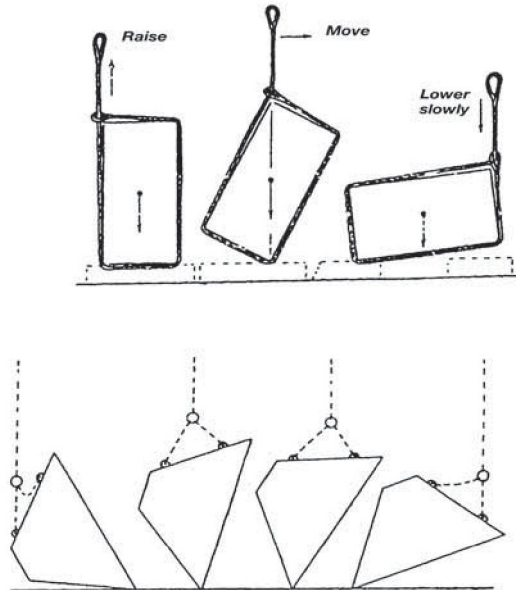

Turning over a steel bin

Chapter 9 Selection and use of mobile cranes

Before commencing a job with a mobile crane, go to the work site with the supervisor and the crane operator and assess the crane suitability for the whole job. Assess access, room, soil, lift capacity and lifting equipment.

Decide where to set up and how to set up.

Mobiling

Some mobile cranes are better suited than others to travel over rough surfaces. Always check the load chart and the manufacturer's recommendations before mobiling.

Cranes are more likely to overturn 'offroad'. Before leaving the road check:

- for potholes and soft or rough ground
- for overhead obstructions
- for powerlines
- for personnel working in the area
- blind corners
- traffic flow
- underground services.

Always check grassy surfaces for potholes hidden by long grass. Walk over the whole area before guiding a crane across.

Make sure spring lockouts (where fitted) are set before mobiling a load.

Do not direct the operator to slew unless the surface is firm and level. Booms are not made to withstand sideways forces.

Slewing can be very dangerous if the crane is attached in any way to another crane or tackle. (The whole operation must be under the control of one person.)

The load should be connected to the crane by a tail rope to prevent sway that could cause the crane to overturn. Do not mobile heavy loads with crawler cranes unless the ground is firm and level.

Take extreme caution walking a load into position with the load high and close to the boom. The load can swing back and hit the boom causing it to collapse as the crane moves forward.

When a crane is used as a winch make sure that the crane is secured in position and immobile.

All mobile cranes with wire rope luffing gear must have a luffing overwinding limit device.

The load must be secured in a fore and aft position unless the load is too long. Long loads must be secured in a diagonal position with the boom fore and aft.

Warning lights (where fitted) must be turned on when the crane is moving.

Travel slowly to prevent excessive swing.

Always carry the load as close to the ground as possible.

Do not direct the load higher until it is almost in position.

Avoid travelling the crane over potholes, depressions, soft ground or across a slope, road cambers or shoulders, rail tracks, or any objects or dunnage wood, which could destabilise the crane or load.

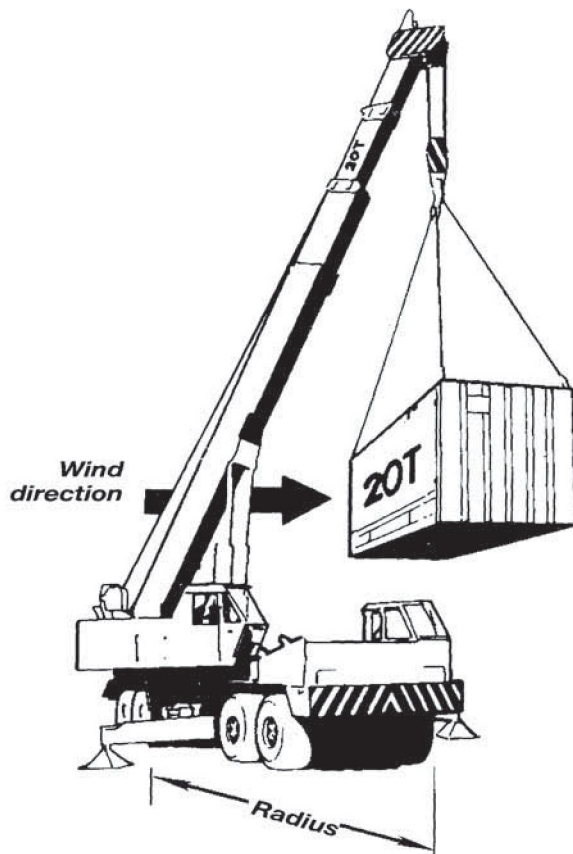

Take the wind pressure into account when working at near maximum capacity.

Observe traffic rules, watch intersections, and avoid pedestrians. Instruct the operator to use the warning horn or whistle when approaching pedestrians or workers.

Warn everyone in the area of your intention before moving the load. A person can be easily knocked from a structure or crushed by a moving load.

General rules for mobilising up and down slopes:

- take the slope and angle of the boom into account when moving up or down a slope
- the load must face uphill

The load must always face uphill as close to the ground as possible

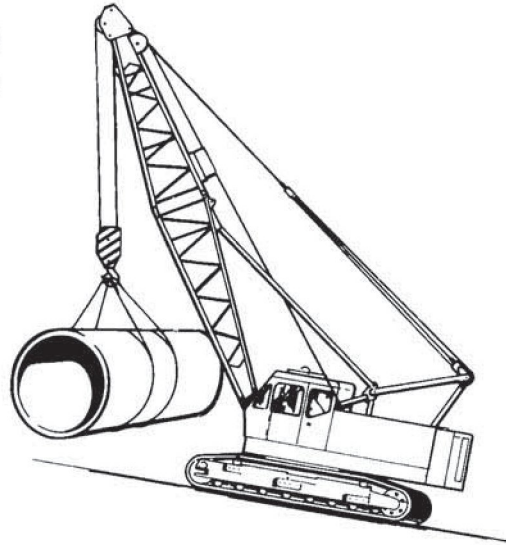

- when mobilising on a slope with the boom facing uphill ensure that the boom angle does not become too close to vertical. This is to prevent the boom toppling over backwards
- do not travel across a slope with a load
- crawler cranes are very dangerous on sloping ground. Direct the operator to boom down before mobilising a crawler crane up a slope. Once the crane reaches the top the operator must boom up to compensate
- where necessary use another crane to steady heavy crawler cranes when they are travelling downhill.

Crane safety

Make sure that the WLL of the hook is at least equal to the maximum load that can be safely lifted by the crane at the given radius and boom position.

Check the hook block for corrosion in the shank and for distortion, cracks and wear in the hook.

Make sure that the hoist rope is completely without twists and turns before lifting where the hook block is supported with multiple falls of rope.

Keep well clear of the lower hoist block sheaves to prevent fingers or hands from jamming in the sheaves.

Make sure that all tyres are inflated to the correct air pressure.

When lifting heavy loads the boom will pull down as it takes the weight thus putting a forward swing into the load when it is raised. To allow for this, take the strain then boom up or alternatively position the hook slightly closer to the crane.

***Always stand
well clear of a
slewing crane***



Make sure that when lifting broadside with a mobile crane on a slope, the downside wheels are raised by solid packing so that the crane chassis is level.

Always stand clear of loads being lifted or handled.

Make sure that slewing cranes are clear of all obstacles, loads and people. Bystanders can become jammed between cab, counterweight and chassis.

For cranes of less than 5 tonne capacity, the lower hoist block must be safeguarded to prevent injuries to hands or fingers.

Swinging from the high side to the low side without altering the boom angle increases the radius – can cause overturning

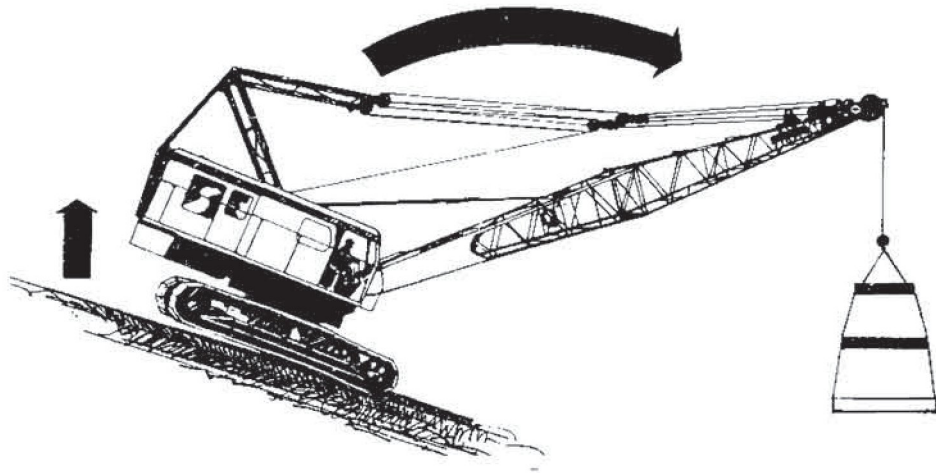

The side loads on the boom caused by working on a slope can result in boom collapse

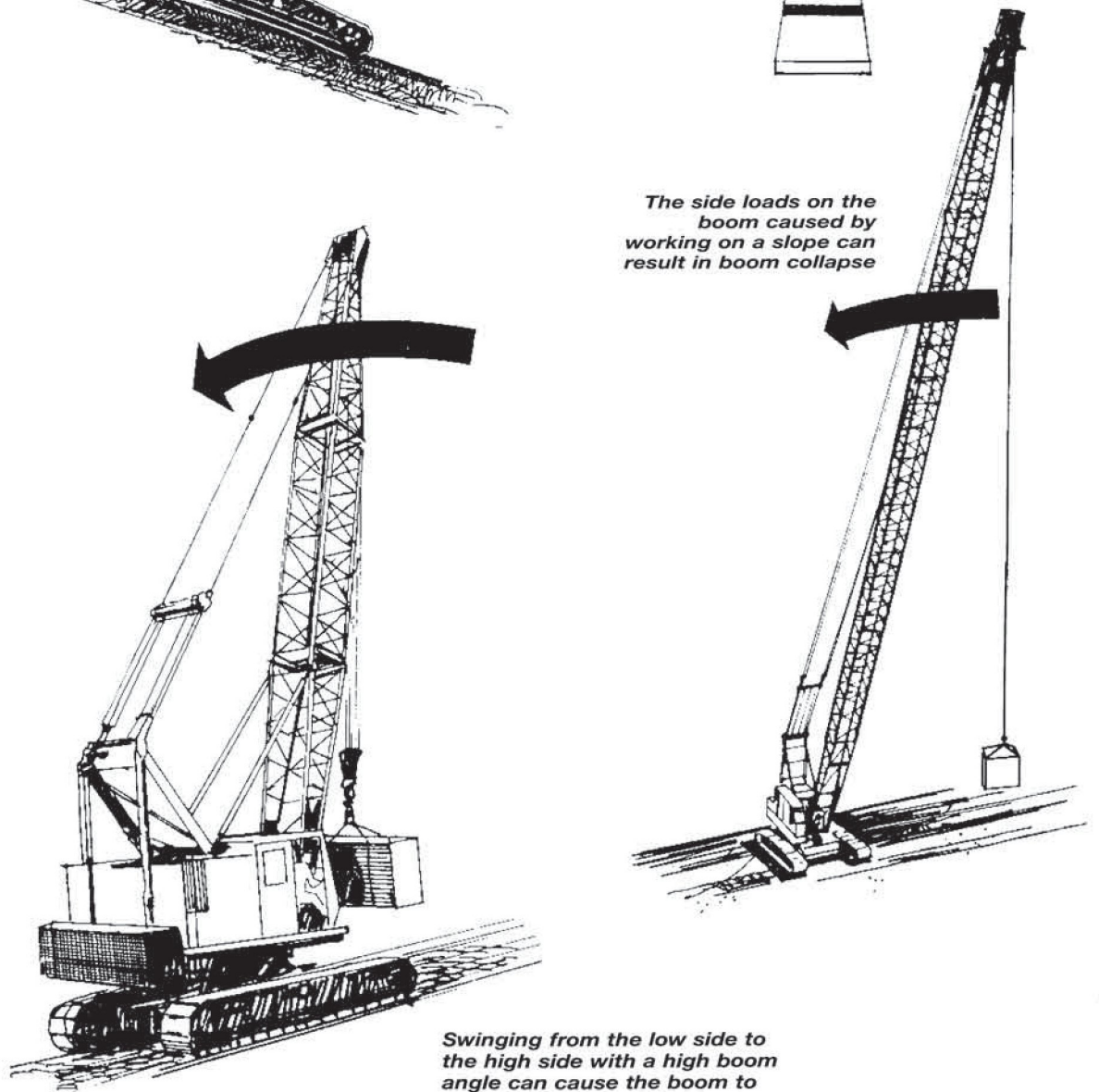

Swinging from the low side to the high side with a high boom angle can cause the boom to collapse back over the crane

When lifting a load on a floating vessel carry out the operations quickly and cleanly. When placing a load onto a floating vessel 'inch' the load slowly into place to prevent the vessel surging.

Crane hoist falls must not be secured to floating vessels for towing or mooring purposes.

Electrical hazards

Always maintain a safe distance from electrical wires when travelling with the boom raised.

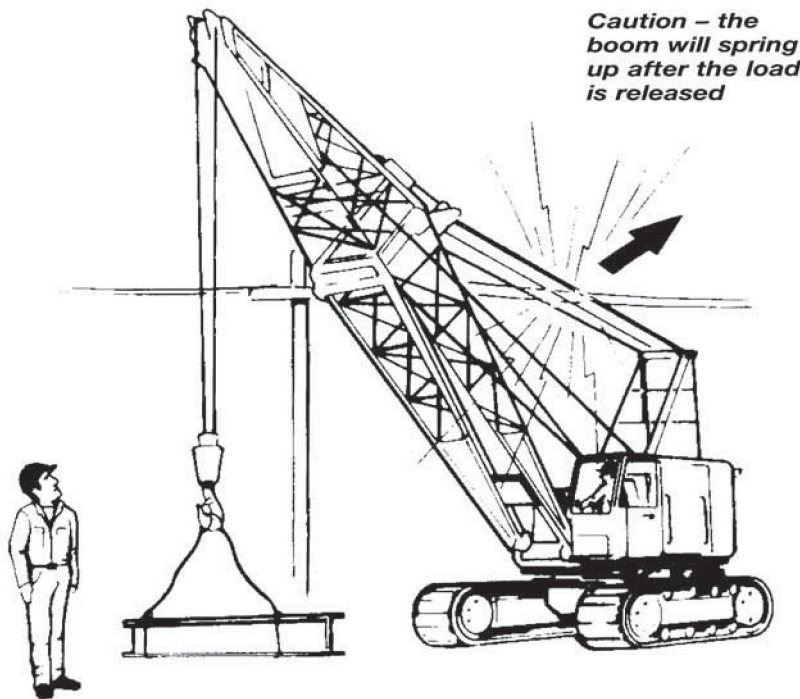

The head of a long boom will spring up when the load is released. Make sure there is a safe distance from any electrical conductors or other obstructions before releasing the load. Do not set cranes up close to any electrified equipment or apparatus unless there are safeguards to ensure the safety of persons using the crane.

All types of crane must not approach closer than:

- 3 metres from distribution lines on poles
- 6 metres from transmission lines on towers.

Caution: In some cases transmission lines can be found on poles.

Keep a look out for possible contact with electrical equipment at all times while operating or travelling the crane. If the crane could come within any of the above distances to electrical apparatus during operation, an observer must be appointed to keep watch and if necessary to warn the dogman.

Advise the crane operator if the crane is in close proximity to electrical equipment. If unsure about the voltage maintain a distance of 6 metres from wires.

Where possible de-energise electrical equipment or use buffers or stops to prevent any part of the crane from coming close to electrical equipment. This is the responsibility of the contractor and the local electricity supplier.

Always use a 16mm dry natural fibre rope as a tag line. Some synthetic fibre rope can conduct electricity in some circumstances.

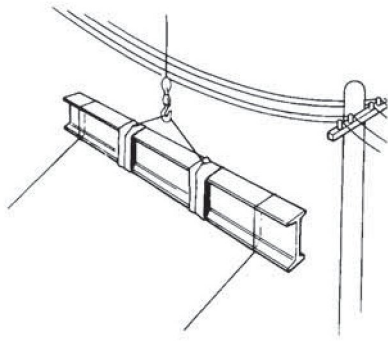

Use dry natural fibre rope tag lines to control a load near to power lines

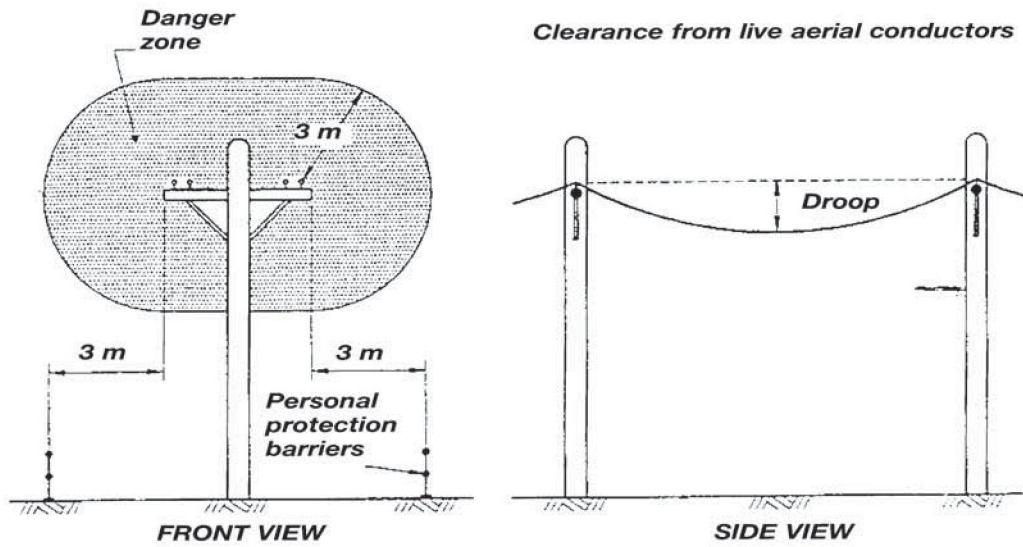

(a) Distribution lines on poles

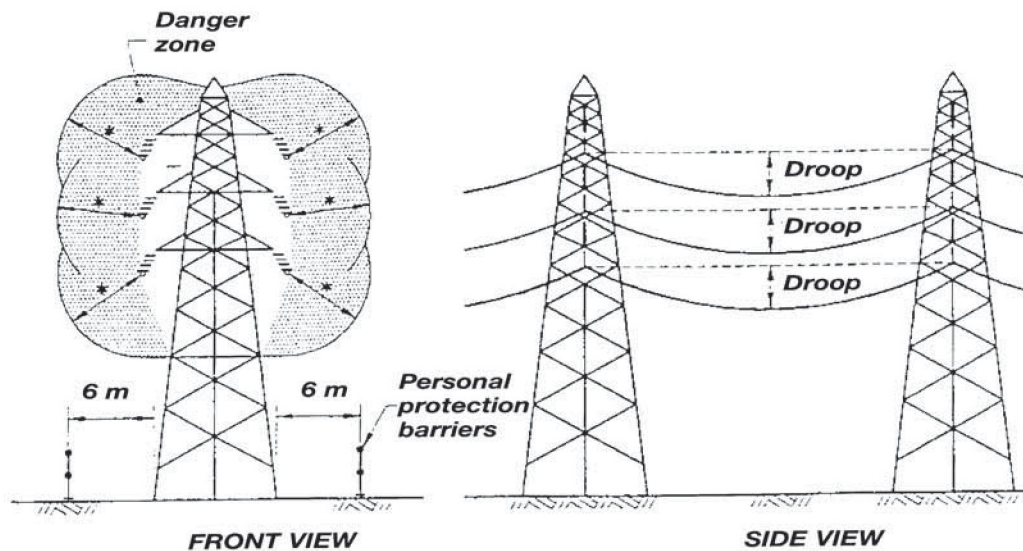

*** Distance 6 metres unless designated otherwise by electricity supply authority**

(b) Transmission lines on towers
Dimensions in metres

Outriggers

Outriggers are hinged or sliding beams that are usually secured with locking pins or check valves. They must be secured when they are retracted.

Outriggers should be packed to keep the crane level and stable when in use. General rules for packing under outriggers:

- outriggers should be fully extended wherever possible
- make sure that the ground under the packing is firm and can bear the load
- the packing must cover as much area as possible to distribute the load
- the base layer of packing should be laid closely together and be at least 75mm thick
- the top layer of packing must be at right angles to the direction of the outrigger beam and at least 200mm wide
- the packing should be hardwood free from defects. Where Oregon is used, beware of cracks
- the packing must be 'pigstyed' (each layer at right angles to the next)
- check the condition of the jacks and packing regularly during crane operation - packing will often loosen up during initial use as the ground settles.

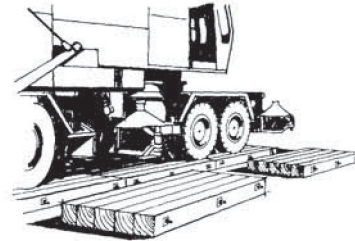
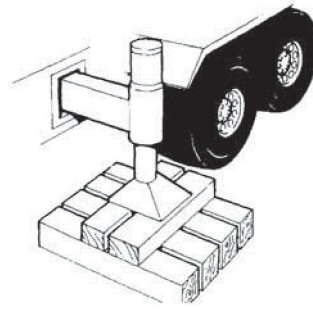

If the ground is soft, large timber mats should be used to provide stability

Consult the load radius (or boom angle) indicator and load chart to find the maximum load that can be lifted:

- when the crane is on outriggers
- when it is not on outriggers.

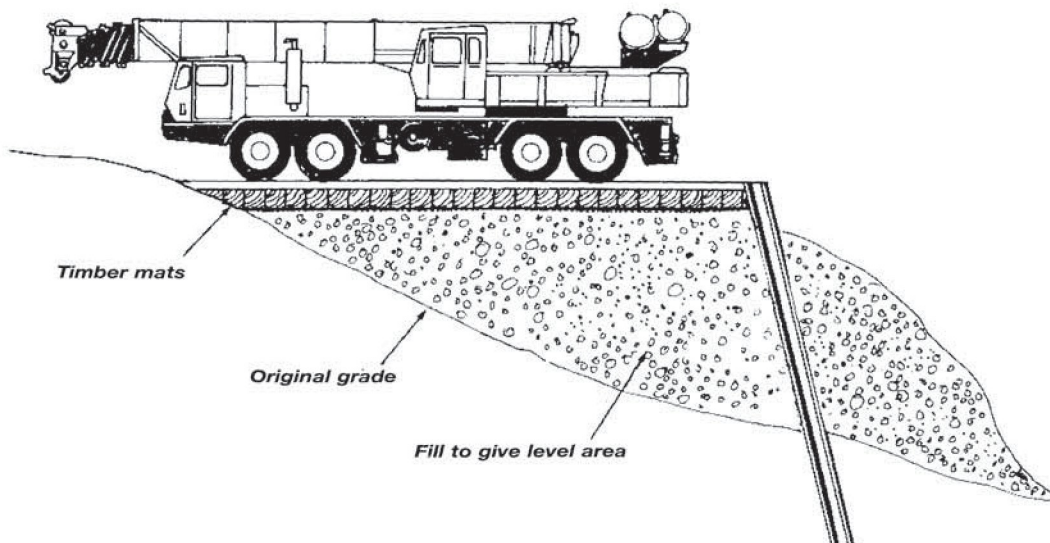

In cases where operation on slopes cannot be avoided, the operating area should be built up to give a level base

The load chart on the crane must display the maximum load that can be lifted in all areas of operation. These may typically include:

- the working zones of slewing cranes
- with any length of boom or jib
- at any radius of the load from the centre of the crane
- with no packed outriggers at the ends
- with no packed outriggers at the sides • with the crane stationary on outriggers
- during mobilizing.

To tighten packing under non-hydraulic outriggers, raise the boom high and slew the boom broadside, then tighten the packing under the boom. Repeat for the other side.

Slewing must be carried out slowly. Slewing places great strain on the boom, clutch, pinion and races. The strain is greater still if the load develops excessive swing.

It is important that the area of the base of the outrigger packing is large enough to safely take the load. To make an estimate of the area needed use the formula below.

The formula for calculating the area of each outrigger base of lattice boom cranes in square metres:

$$\text{Area of base} = \frac{W \times R}{B \times N \times V}$$

For a calculator:

$$\text{Area of base} = W \div R \div B \div N \div V$$

W = Load plus half the mass of the boom in tonnes

R = Distance from load to back wheel support in metres

B = End of outrigger to back wheel in metres

N = Number of outriggers on the loaded side

V = Bearing pressure of soil

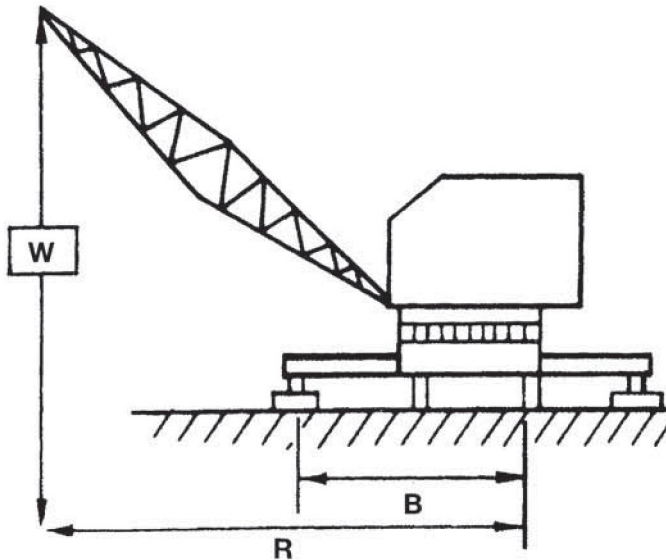

Use the table below for estimating the load bearing pressure (V) of different soil types.

SOIL TYPE	Pressure (V) Tonnes per sq metre		
		Ordinary clay and dry sand mixed with clay	20
		Dry sand and dry clay	30
Soft clay or loam	10	Hard clay and	
firm coarse sand	40	Firm coarse sand and gravel	50
sandstone	80	Shale rock and	
Hard rock	200		

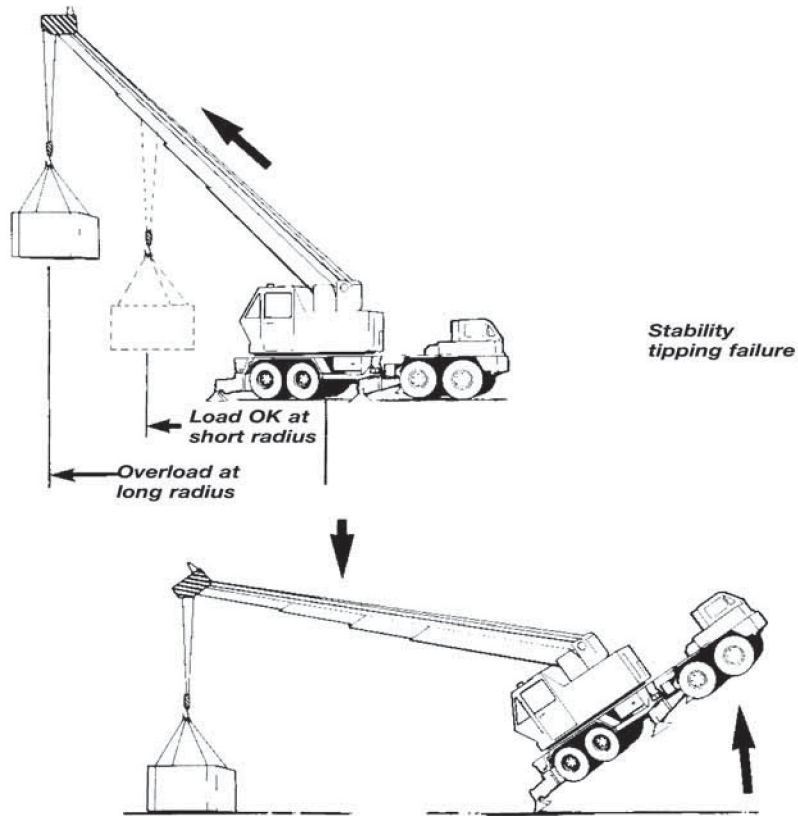

OR

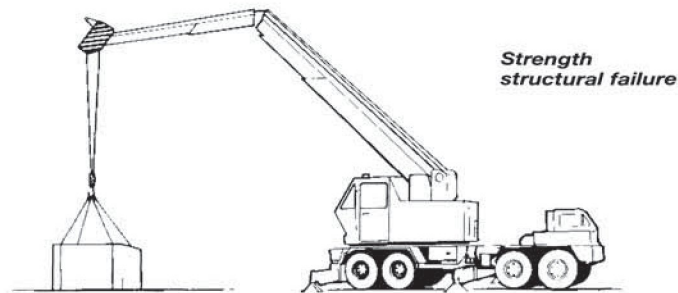

The load must always face uphill as close to the ground as possible

For example:

A load of 10 tonnes on a 2 tonne boom is to be lifted 7 metres from the back wheel support. There are two outriggers four metres from the support. The soil type is soft clay.

$$\frac{\text{Area of base} = 11 \times 7}{4 \times 2 \times 10}$$

or

$$11 \times 7 \div 4 \div 2 \div 10 = 0.96 \text{ sq m}$$

NB: Where the boom is used over one outrigger the area of the packing must be increased by 40 per cent.

Locomotive cranes

Always chock the wheels and apply the travelling brake when operating locomotive cranes on a slope, however slight.

Make sure that the outriggers are fully extended and properly packed before lifting.

Use running lights and warning flags.

Fit a derailing stop at the front and back of the crane, or open any suitably located switch points to divert run-away trucks.

Make sure that the crane is as level as possible. If necessary, the crane outriggers (where fitted) should be packed.

Watch out for indications of possible derailment.

Do not use the crane boom to assist rerailment in the event of a derailment. Severe overloading may result. Instead use mechanical or hydraulic jacks and packing, or another crane of suitable capacity.

Do not use rail clamps in place of outriggers to prevent the crane overturning, as they are only suitable for preventing the crane from moving along the track. If the crane overturns the rails and sleepers may also overturn if rail clamps are used.

Please note: For lengthening or shortening the boom on mobile cranes see Chapter 20 *Rigging cranes and hoists*. For multiple crane lifting see Chapter 18 *Multiple crane lifting*.

Chapter 10 Packing, securing and moving loads

Packing

Packing must be able to support the load and the base of the footings of packing should be hard and level. If the footing is earth, a layer of sand should be spread over the area. Make sure that the base area of packing is large enough to support the load.

Check that there are no services such as large diameter pipes, tanks and cellars under the packing, especially if a heavy load is to be placed on the packing.

Do not place bearers in line above one another, as the packing can roll and collapse.

During lifting operations, keep filling the gap with packing until larger bearers can be inserted. Follow up packing must be adjusted as the load rises.

Pigsties or cribbing

Pigstyng is an effective method of supporting a load with criss-crossed timber packing. Each layer is set at 90° to the layer below.

The footing base must be large enough to support the load and the main load support bearers must be at right angles to the load.

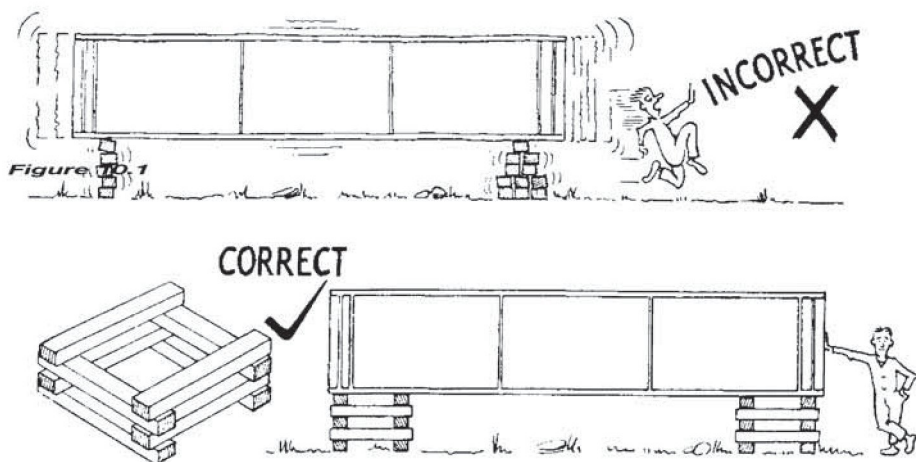

Sleepers which are all slightly different sizes are often used for pigstyng. To ensure there is no movement the second layer must be packed with wedges or thin packers (gluts).

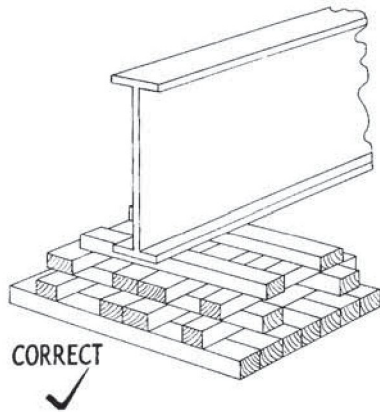

Parbuckling

Parbuckling is a method of using two parts of rope to unload drums or cylindrical objects from trucks, or to roll them up or down inclines.

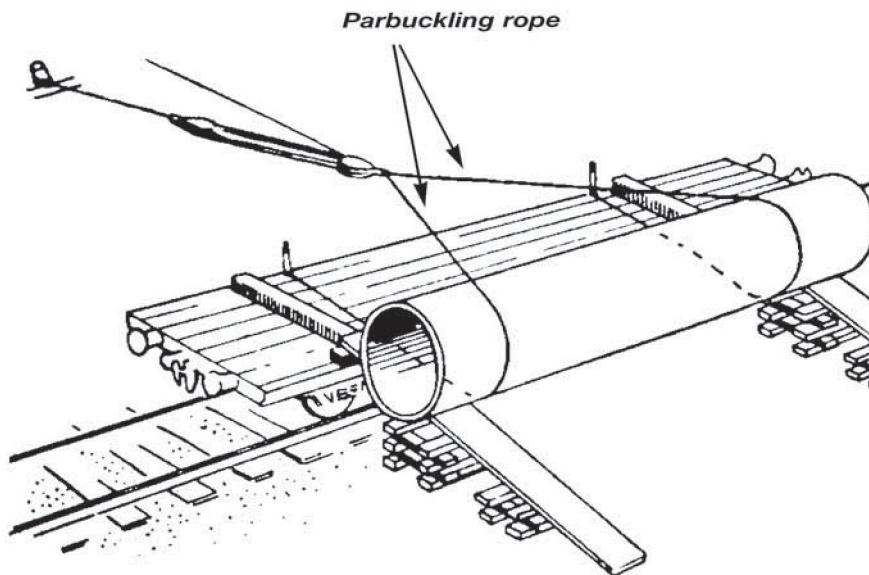

NOTE: For heavy loads it is recommended that one or two completed turns be taken round the object with the parbuckling rope. For exceptionally heavy loads two separate parbuckling ropes and purchases should be used, one at each end of the object.

Attach one end of each part to an immovable object. Take a round turn around the cylinder and secure the free end to another suitable anchorage for slackening away as the load is allowed to move away. To maintain control over heavy objects use a purchase or tackle.

When using only one parbuckle rope make sure that the load can be lowered evenly. If two parbuckle ropes are used both must be slackened evenly.

Use parbuckle rope in the centre to start the load moving and also to act as a restrainer when the load is rolling.

Please note:

- the rope must be strong enough and long enough to do the job
- skids or bearers must be rigidly fixed

- all persons must be kept away from both front and rear of the load.

Rolling objects

Rollers can be used where the loads are bulky or heavy, and there is no room to lift the load into position by crane. The surfaces underneath should be level and hard. Sole planks may be used to provide a level surface if the ground is uneven.

Types of rollers:

- steel scaffold tube for light loads
- solid steel bar for heavy loads
- timber rollers or logs for 'bush jobs'.

Timber bearers should be placed on the rollers and the load landed on bearers giving the rollers two even surfaces. The bearers must be of sufficient thickness to clear any projections from under the load. Alternatively, a special cradle may be used.

The use of rollers for moving heavy objects

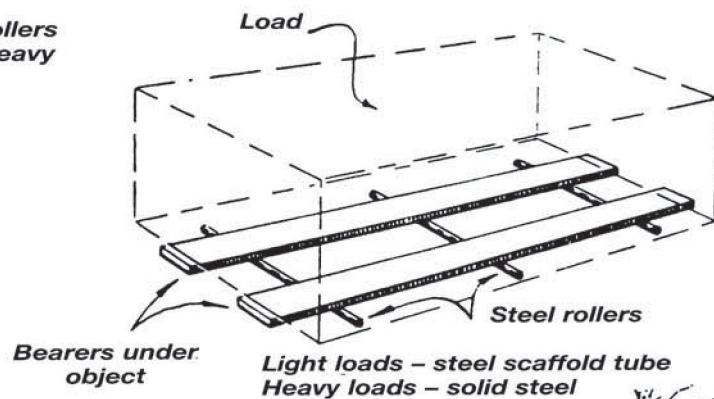

Note: Sole planks are required when rolling over uneven ground

The use of sole planks over uneven ground

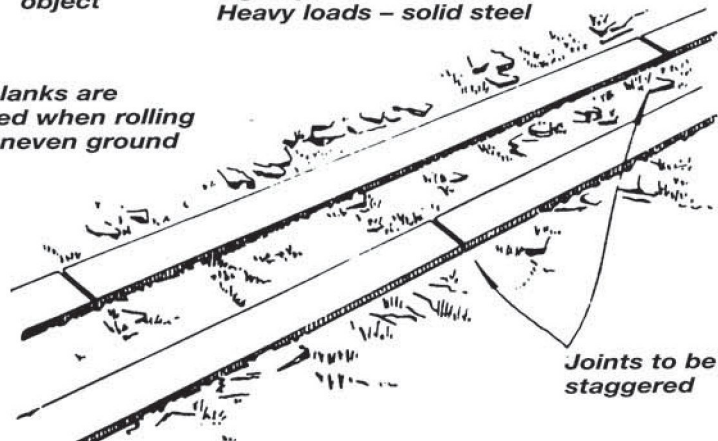

Use at least three rollers to ensure that the load does not become unbalanced and topple off. Place rollers at an angle to change direction of movement.

Hands and feet must be kept clear from the rollers while the load is moving.

Skidding

Skidding is where the load slides into place on skids set up on rails. To skid a heavy load set up well greased rails strong enough to support the load on sleepers.

Loosely bolted fish plates must be used to join the rails together. Each rail must be packed above the next rail in the direction of movement.

The sliding shoes should be constructed of steel channel sections slightly turned up on the ends of the web and slightly turned outwards on the ends of the flange.

Timber bearers should be placed across the rails on the shoes at various positions to suit the balance of the load. The bearers must be strong enough to support the load in the centre.

When the load is in motion care must be taken to ensure that the shoes and bearers travel evenly.

Skids should be packed level to prevent the load from working or toppling sideways.

Where necessary, a restraining purchase should be fitted to the rear to obtain better control of the load.

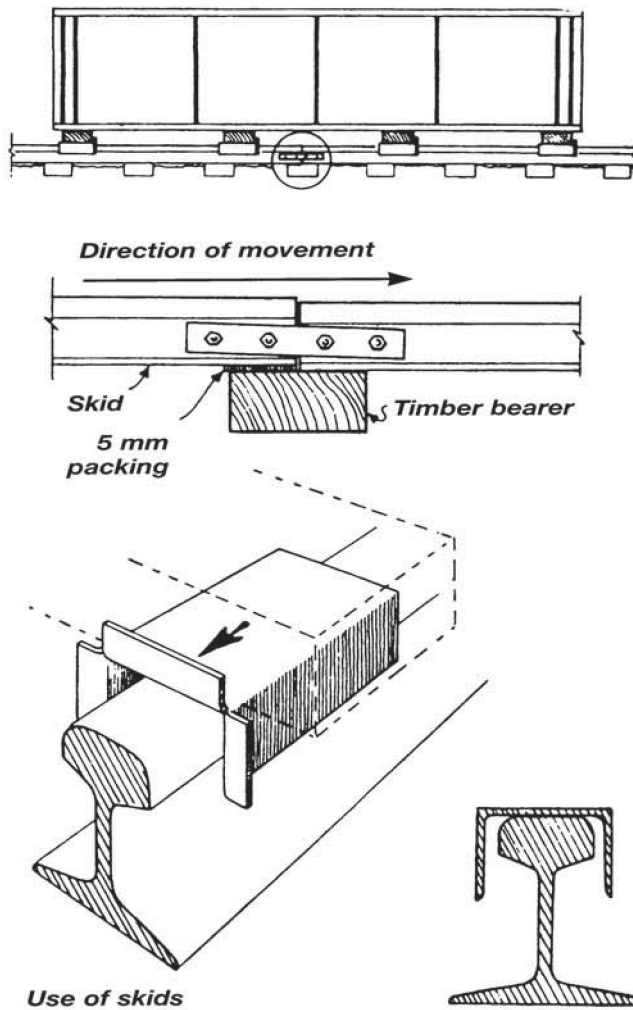

Steel wedges

When driving steel wedges take care that follow up packing is inserted, as the wedges can fly out.

When driving wedges keep well clear of the rear of the wedge as they fly out with extreme force. Secure the wedge with a lanyard, especially when working at a height.

When driving more than one wedge try to synchronise the blows on each. If steel wedges are fixed, extreme care must be taken when withdrawing them, as they fly out with great force.

Be careful of the fingers when placing or removing wedges or packings. Hold packing by the end and keep fingers well clear.

Grind off all burrs or mushroom heads on steel wedges as they fly off and cause serious injury.

Skates

Skates are a method of moving heavy loads with a set of small rollers fixed into a solid frame which are set in bearings and run very freely. They are built to hold a specific safe working load which should not be exceeded.

Prior to use:

- sweep clean the area in the direction of travel so that there are no obstructions to jam the skates
- ensure that the surface is strong enough to take the weight of the load displaced over the small area of the skate, or skates, and that the skates will not damage the surface
- ensure that the skates are placed under the load in a position so that there is even loading on every skate and that the load is level. If this cannot be done bearers must be placed under the load to ensure even loading
- ensure that there are personnel to keep watch for the load shifting dangerously while it is moving
- ensure that all skates run freely and that there is no damage to them.

Do not move a load on skates quickly. Use a restraining purchase at the rear to ensure that the load does not 'get away'.

Skates can be reversed so that the skates remain stationary and the load runs over them. During this procedure make sure that the load does not run off the skates and topple over.